

The  
401

# INTERMEDIATE MATCUTTER

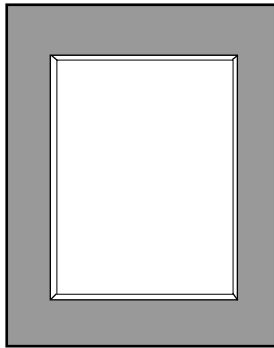

40" Mat cutting system  
with production stop,  
straight and bevel  
cutting heads

  
**LOGAN**<sup>®</sup>  
GRAPHIC PRODUCTS, INC.  
*Tools for Art - Tools for Life*  
[www.logangraphic.com](http://www.logangraphic.com)

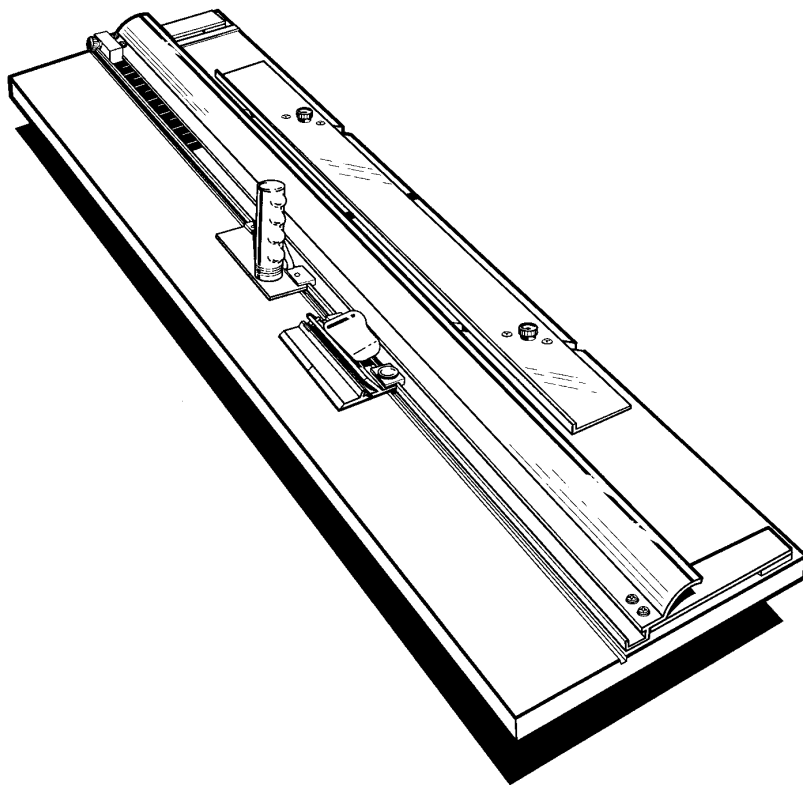

## INSTRUCTION AND OPERATION MANUAL

Purchase Date \_\_\_\_\_

I.D. Number \_\_\_\_\_  
(On Board Bottom)

# INTRODUCTION:

*Congratulations on your purchase of the Logan Intermediate Mat Cutter* The Intermediate is a well designed mat cutter combining the best of what Logan mat cutters have to offer. Features like a pivot and pull bevel cutter with Anti-Crawl pin, Straight cutting head with an ergonomic handle, scaled production stop, parallel Mat Guide, and the flexibility to add additional accessories like a glass cutter and surface V-Groover make the Intermediate the a cost-effective and useful tool for artists, crafters, photographers and framers. This instruction manual is written to acquaint you thoroughly with the product. Please take some time to familiarize yourself with it before cutting. You will find that the time taken will be well worth it, and you will be cutting professional mats in no time.

## TABLE OF CONTENTS:

Introduction	1
Warranty	1
<hr/>	
Check Of Contents	2
Identification Of Machine Components	2
<hr/>	
Orientation	
A. Assembly	3
B. Blade Installation	3
Operation	
A. Straight Cutting A Board To Size	4
B. Cutting A Beveled Opening	4&5
C. Cutting a Beveled Opening Using the Stop	5
D. Cutting A Straight Opening	6
<hr/>	
Adjustments & Maintenance	
A. Blade Depth Adjustment	6
B. Re-Parallel The Mat Guide	7
C. Helpful Hints	8
<hr/>	
Parts List	
A. Cutting Heads	9
B. Board	10
<hr/>	
Trouble Shooting	11
<hr/>	
Creative Matting Guide	
A. Double Mat	13
B. Off-Set Corner Mat	13
C. Inlay Mat	14

### **Warranty**

Logan Graphic Products, Inc. ("Logan") warrants the **401 INTERMEDIATE** to be free from defects in parts and workmanship for a period of two years from the date of original purchase. Logan warrants that it will either repair or replace, in its sole discretion, any necessary replacement parts found to be defective. Should the product need to be returned to Logan for repair or replacement parts, **authorization for any return must come from Logan in writing. Costs of returning the product to Logan, including insurances, shall be borne by the purchaser.** Logan shall not be liable for any damages or losses, incidental or consequential, direct or indirect, arising from the use of this product. This warranty extends only to the original purchaser and is not assignable or transferable. This warranty is in lieu of all other warranties, expressed or implied.

**Logan Graphic Products, Inc.**  
1100 Brown Street  
Wauconda, IL 60084  
800/331-6232

## CHECK OF CONTENTS:

**401 INTERMEDIATE** 45" Cutting board with Mat Guide, Squaring Bar, Backing Sheet, Straight and Bevel Cutting Heads, production stop and 1 five pack of Logan #270 blades.

## IDENTIFICATION OF MACHINE COMPONENTS:

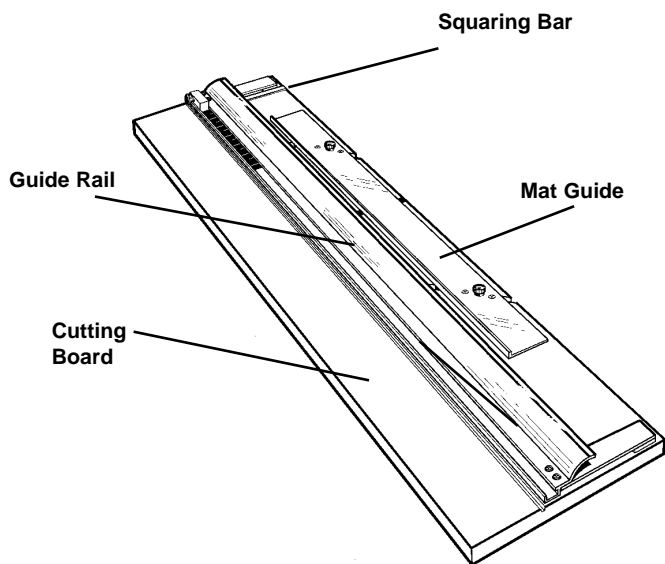

### 401 Cutting Board

**Guide Rail-** Used to guide cutting heads while in use.

**Mat Guide-** Used to set the border width of a mat and keep the mat in position.

**Squaring Bar-** board mounted 90 degree bar used to hold mats square when cutting and as stop when bevel cutting.

**Cutting Board-** Vinyl covered base board of machine.

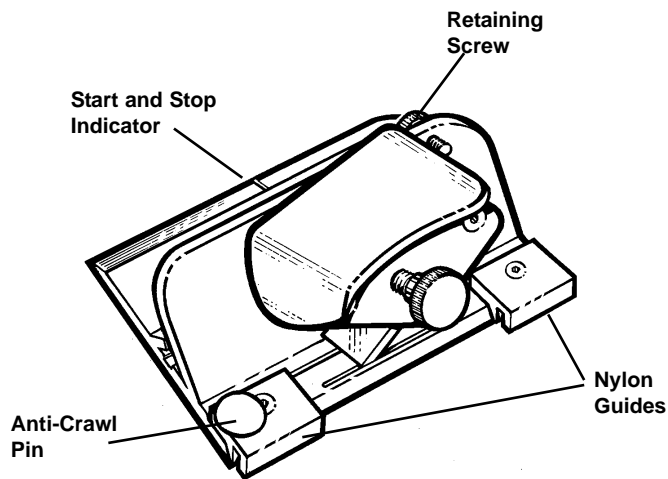

### Bevel Cutting Head

**Start and Stop Indicator-** Line which shows where to begin and end cut.

**Retaining Screw-** Screw which keeps blade safely in slot when not in use.

**Anti-Crawl Pin-** Prevents cutting head from creeping forward during initial penetration of blade into mat.

**Nylon Guides-** Guides which allow Bevel Cutting Head to hook onto Guide Rail.

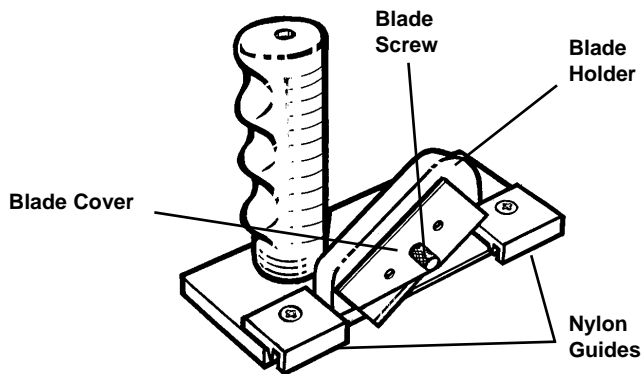

### Straight Cutting Head

**Blade Holder-** Block which holds blade in place while cutting. Has three separate depth settings.

**Blade Cover-** Covers blade on Blade Holder.

**Blade Screw-** Holds blade in place inside Blade Holder.

**Nylon Guides-** Guides which allow Straight Cutting Head to hook onto Guide Rail.

## ORIENTATION

The Procedure detailed in the following instructions refer to the right and left side, and the top and bottom of the machine as shown. **Fig . 1**

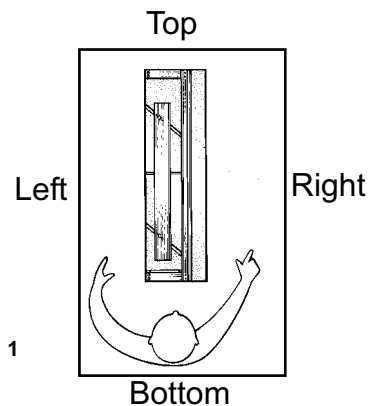

Fig 1

## A. Assembly

### Mat Guide

To loosen, turn knobs three full turns and push down with thumbs to hear the knobs click and release. **Fig . 2**

### Backing Sheet

A Backing Sheet is a piece of scrap matboard placed underneath the mat to be cut when bevel cutting. The Backing Sheet must be at least as long as the mat being cut and at least 4" wide. This protects the blades while cutting and produces a better cut. **Fig . 3**

*NOTE: It is important not to continue to cut in the same spot of the Backing Sheet as this can cause curves in the cut. Replace Backing Sheet as necessary.*

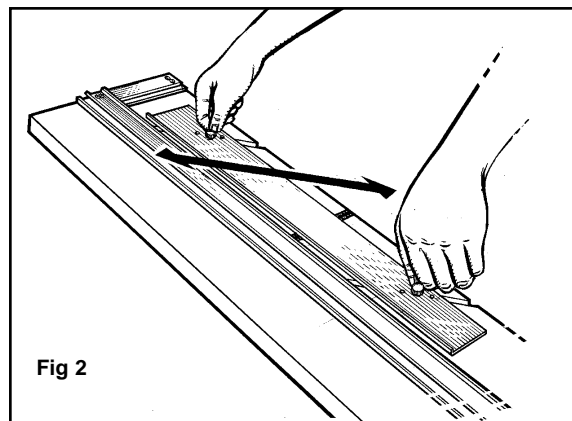

Fig 2

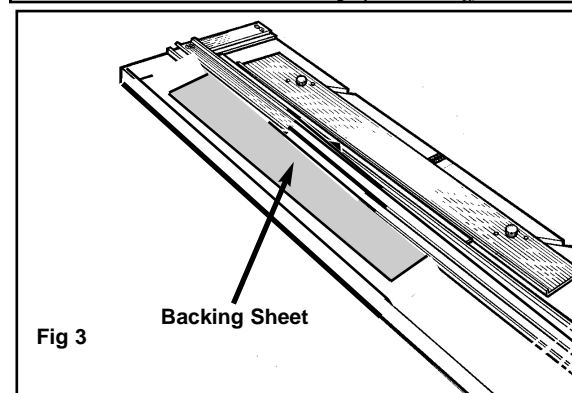

Fig 3

## B. Blade Installation

### 701 Straight Cutting Head

Remove the Blade Screw and the Blade Cover from the Blade Holder. Place one #270 blade, sharp edge down, in the slot on the Blade Holder and line up the hole in the blade with the desired depth setting. Replace the Blade Cover and Blade Screw. **Fig. 4**

*NOTE: Always have the three holes on the Blade Cover lined up exactly with the three holes on the Blade Holder before replacing the Blade Screw.*

### 702 Bevel Cutting Head

Loosen the Retaining Screw found on the back side of the Cutting Head until flush with the surface of the base. This allows the Blade Holder to tilt back all the way for blade change. Slide one #270 blade all the way in the back of the Blade Holder as shown. **Fig. 5**

*NOTE: The hole in the blade is not designed to line up with the Blade Screw.*

Re-Tighten the Blade Knob and tilt the Blade Holder down allowing the tip of the blade to enter the Blade Slot. Retighten the Retaining Screw.

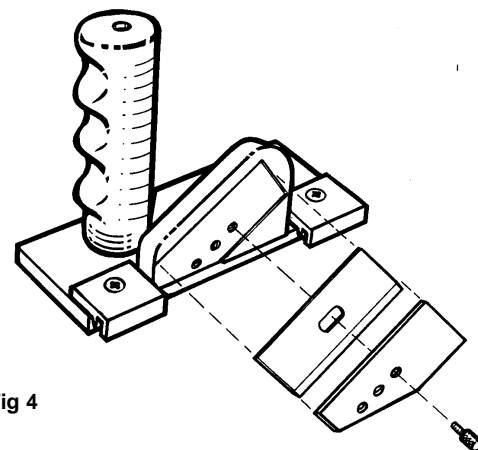

Fig 4

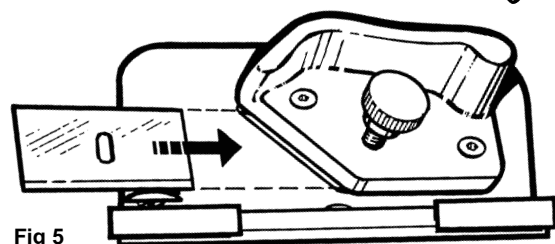

Fig 5

# OPERATION

## A. Straight Cutting A Board To Size

1. Remove the Mat Guide and Backing Sheet before straight cutting.
2. Use a ruler, T-Square or similar device to mark the dimensions of the board to be straight cut.
3. Mark the lines on the back and place the mat color side down underneath the Guide Rail lining up the marked line with the right edge of the Guide Rail and down against the Squaring Bar.
4. Use the Nylon Guides on the Straight Cutter to hook the Cutting Head onto the Guide Rail past the end of the board to be cut. Grasp the handle as shown in the picture and pull the Straight Cutting head towards you. Keep constant downward pressure on the Straight Cutting Head and the Guide Rail as you make your cut. **Fig. 1**

**CAUTION:** Be careful to control the Straight Cutting Head as it breaks through the end of the matboard as it will tend to “jump” towards you.

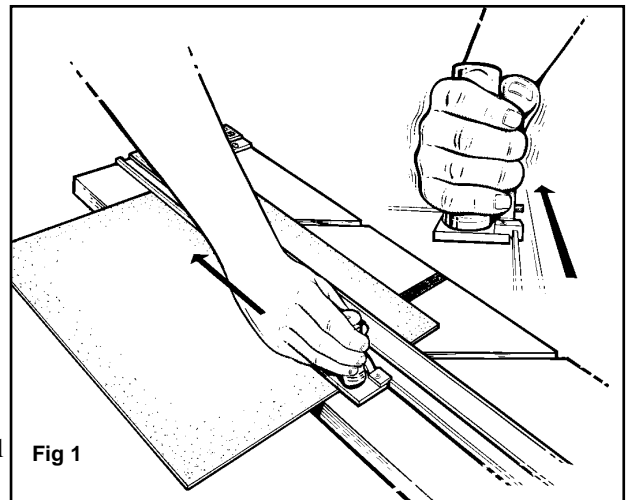

## B. Cutting A Beveled Opening

**EXAMPLE:** Cutting a mat with a 2” border.

1. To re-install the Mat Guide, loosen the Black Knobs three turns and with the raised edge towards the Guide Rail, line up the Mat Guide with the parallel slots. Enter both sides at the same time keeping thumb pressure on the Black Knobs.
2. Set the Mat Guide to the desired border width. For example for a 2” border align the *back* of the Mat Guide at the 2” mark and tighten the Black Knobs. **Fig. 2**
3. Make sure the Backing Sheet is in place before bevel cutting. You *must* use a Backing Sheet. The straight cut slot underneath the Guide Rail is for straight cutting only.
4. Place the mat *color side down* under the Guide Rail, against the Mat Guide and down against the Squaring Bar.
5. Using a pencil, draw a line down the full length of the back of the matboard. Repeat this for the remaining three sides. **Fig. 3**

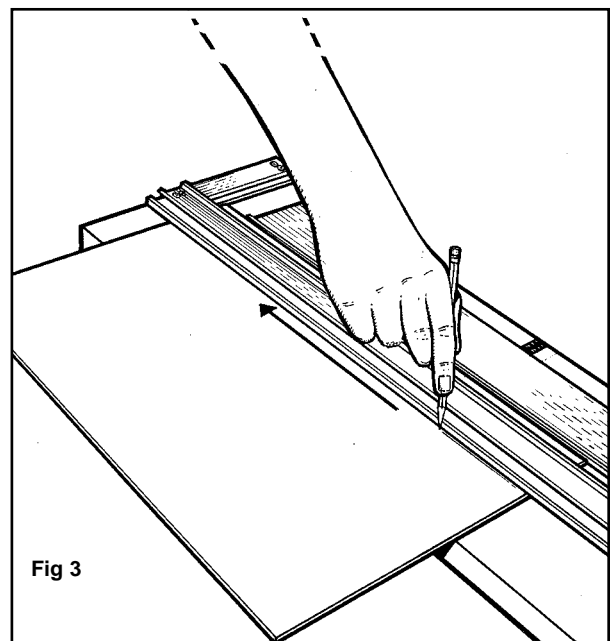
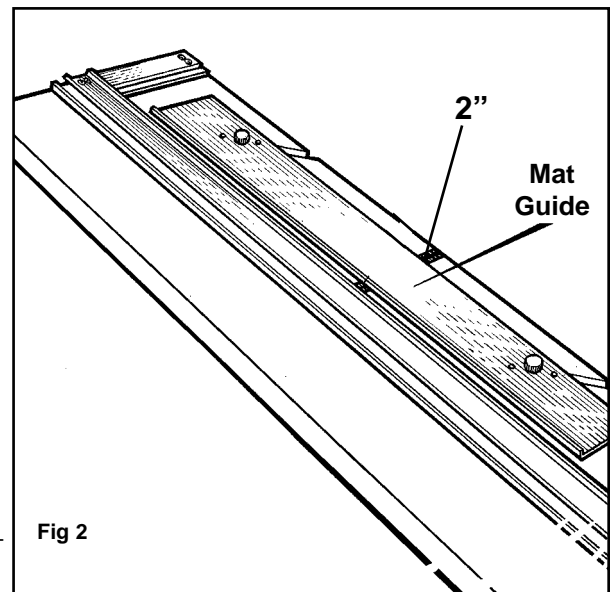

6. Attach the 702 Bevel Cutter to the Guide Rail by fitting the black nylon guides over the raised edge of the channel.

7. Position the cutter so that the Start and Stop Indicator line lines up with the marked line closest to the top of the machine.

8. Depress the Anti-Crawl Pin and firmly pivot the Blade Holder down into the mat. **Fig . 4**

9. Release the Anti-Crawl Pin and pull the cutting head towards you until the Start and Stop Indicator line lines up with the line on the matboard closest to you. **DO NOT GO PAST THE LINE!**

**Fig. 5**

**NOTE: It is essential to keep even downward pressure on the Blade Holder as you cut.**

10. Rotate the Blade Holder back up to the neutral position, turn the mat 1/4 turn to the right and repeat steps 7 through 9 for the remaining three sides.

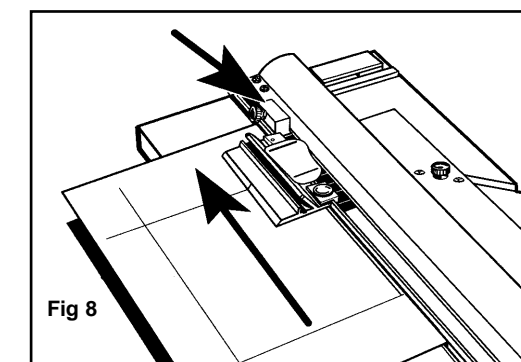
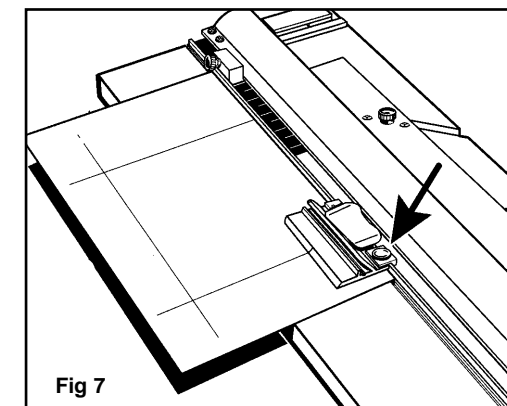
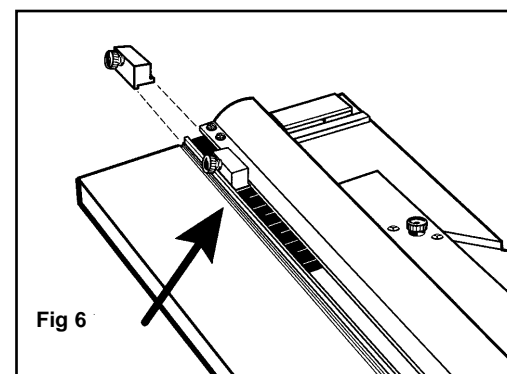
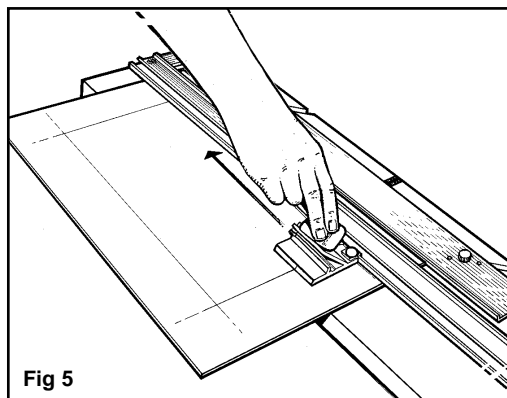
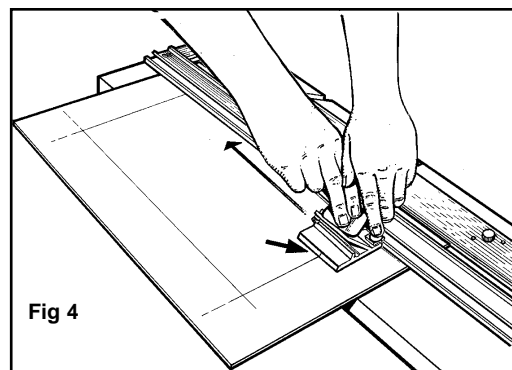

## C. Cutting A Beveled Opening Using the Stop

**EXAMPLE: Cutting a mat with a 2" border.**

1. Repeat steps 1 through 4 from section B.

2. Insert the production stop into the guide rail as shown and set at the 2" mark. Fig. 6

3. Using a pencil, draw one line down the full length of the back of the matboard. Immediately turn the mat clockwise 1/4 turn.

4. Attach the 702 bevel cutter and position the start and stop indicator over the marked pencil line. Fig 7.

5. Depress the Anti-Crawl Pin and firmly pivot the Blade Holder down into the mat. Fig. 7.

6. Release the Anti-Crawl Pin and pull the cutting head towards you until it lightly makes contact with the production stop. Fig 8.

7. Rotate the blade holder back up to the neutral position, turn the mat 1/4 to the right and use the cut line in the back of the matboard to start your next cut. Complete this for all the remaining three sides.

## D. Cutting A Straight Opening

### EXAMPLE: Cutting a mat with a 2" border

1. Set the Mat Guide to the 2" mark on the scale and retighten the Black Knobs.
2. Place the mat to be cut into the machine colored side down with the Backing Sheet underneath and lower the Guide Rail.
3. Using a pencil, mark a line along the full length of the matboard using the Guide Rail as a guide. **Fig 1.** Repeat this for remaining three sides.
4. Using the Straight Cutting Head, align the top scribe line with the top border line and press down on the handle until the cutting head sits flat on the matboard and over the Nylon Guides.
5. Pull the Straight Cutting Head until the bottom scribe line lines up with the bottom border line. Repeat until all borders are cut. **Fig. 2**

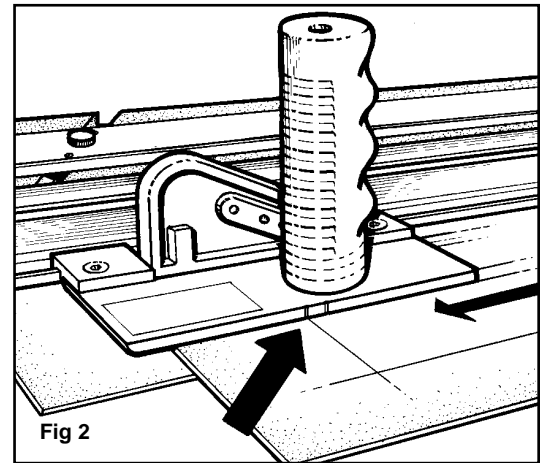
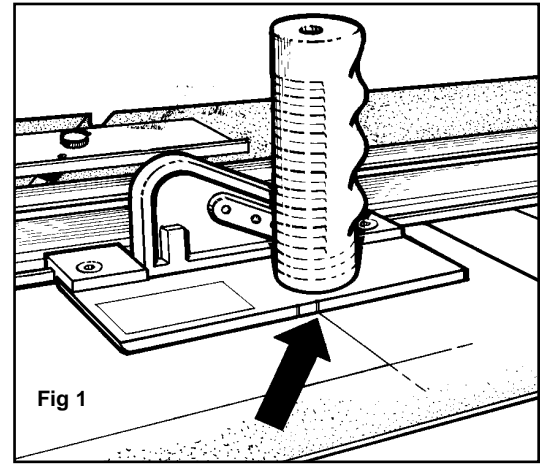

## ADJUSTMENTS & MAINTENANCE

### A. Blade Depth Adjustment- Bevel Cutting Head

#### TOOLS NEEDED: Screwdriver, Ruler

1. Hold the 702 Bevel Cutter upside down in your hand with the blade activated in the cutting position.
2. Looking at the tip of the blade, measure the exposed amount with a ruler at the same angle as the blade. For standard thickness mat board (4 ply) only 1/8" of blade should be seen. To adjust, find the screw head recessed below the bottom of the surface of the cutting head near where the blade is coming out. **Fig. 3**
3. Turning the screw to the right (*clockwise*) will decrease the blade depth, the left (*counterclockwise*) will increase the blade depth. Not all matboard requires 1/8". Thicker matboard will require more. Always have the blade depth set so that the Backing Sheet is scored only slightly. Cutting even half way through the Backing Sheet is entirely too much blade depth. This extra blade depth allows the blade tip to flex and cause hooks and curves in the cut. extra blade depth can also cause the Start and Stop indicator to be incorrect which results in overcuts. This test and adjustment needs to be done periodically as the depth can increase itself over time with regular use.

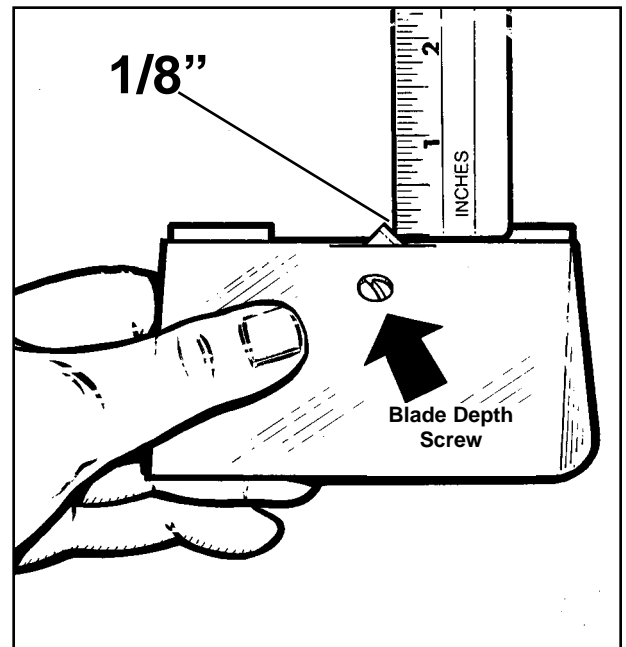

## B. Re-Parallel The Mat Guide

**TOOLS NEEDED: Phillips Screwdriver, Ruler.**

To re-parallel the Mat Guide, first determine that the Mat Guide *is* out of parallel by doing a parallel test.

### Parallel Test:

1. Lock the Mat Guide at the 2" mark on the scale. **Fig. 1**
2. Place a scrap piece of matboard under the Guide Rail and up against the Mat Guide at the far end of the machine.
3. Using a pencil, mark a line from the edge of the matboard into the center then stop.
4. Slide the mat all the way down near where you are standing keeping under the Guide Rail but not against the Squaring Bar.
5. Finish drawing the line all the way across the top of the mat.
6. The piece of matboard should now appear to only have one single line across it. If the two lines drawn do not line up with each other, the Mat Guide needs to be re-parallelled.

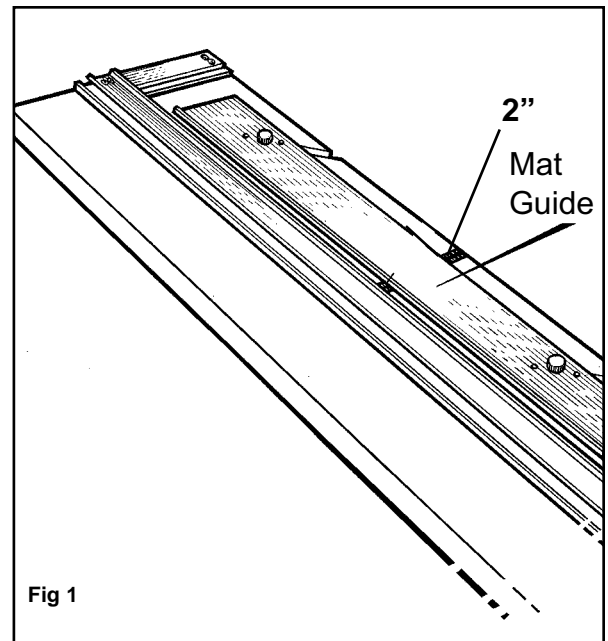

### TO RE-PARALLEL:

1. Release the Mat Guide three full turns and push the knobs down to release.
2. Use a Phillips head screwdriver to loosen the four screws one turn.
3. Place a ruler or straight edge between the Mat Guide and the Guide Rail. **Fig. 2**
4. Slide the Mat Guide against the straight edge and the Guide Rail. Make sure both the Mat Guide and the Guide Rail are making solid contact on both sides of the straight edge.
5. Re-tighten the **Black Knobs** first.
6. Then re-tighten the four screws. Do another parallel test to ensure that the Mat Guide is now parallel.

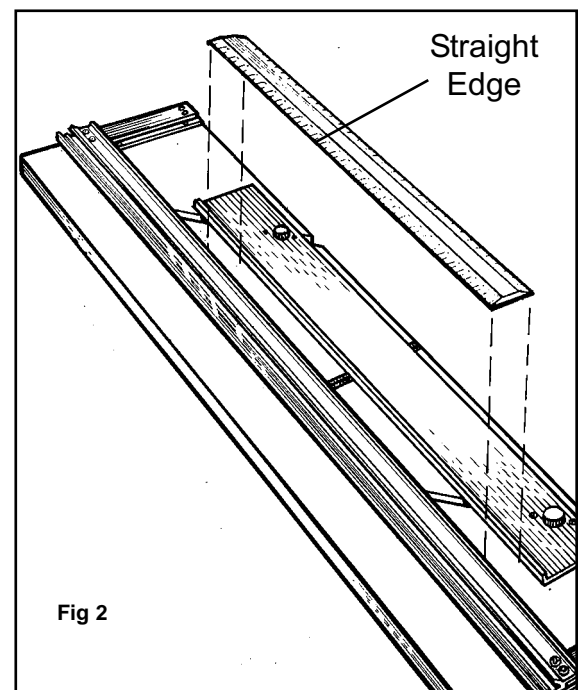

## C. Helpful Hints

1. Always store your Intermediate Mat Cutter flat. Never stand the Mat Cutter up against a wall for any period of time. This can cause the Mat Cutter base to bow. Always see that you are using your #401 Intermediate on a solid flat surface.

---

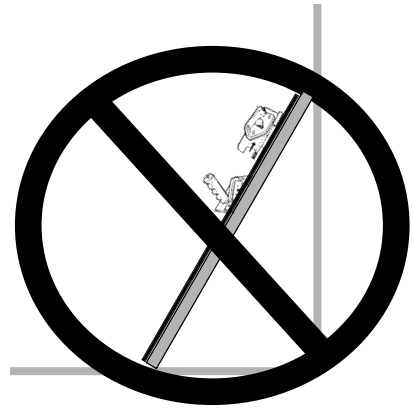

2. If you need to clean the Guide Rail, only use an evaporating solvent (lighter fluid, alcohol) that will leave no residue. Do not lubricate the Guide Rail as the substance will soften the Nylon Guides causing them to bind on the Guide Rail.

---

3. The Bevel Cutting head has a “spring back” action that happens when no blade is installed. This spring action is **not** intended to pull the blade up out of the mat after a cut. It is a safety design to prevent the blade from dropping down into the blade slot and cutting into a table, your hand, etc. when not in use. The tightness of the blade slot is designed to squeeze the blade tip which prevents flexing giving a better finished cut.

---

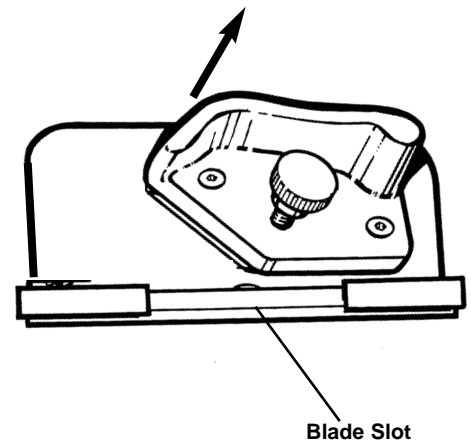

4. When cutting a border less than 1 1/4”, an extra Backing Sheet is needed to allow the Guide Rail to properly seat down on the mat board. Not adding this step causes the Guide Rail to hang up on the Black Knobs of the Mat Guide.

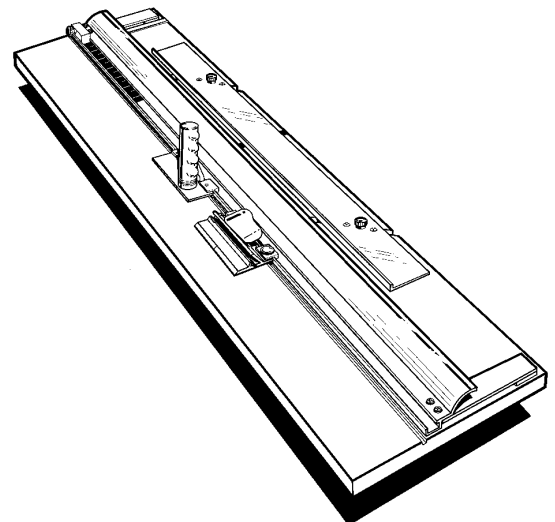

# Parts List

## A. Cutting Heads

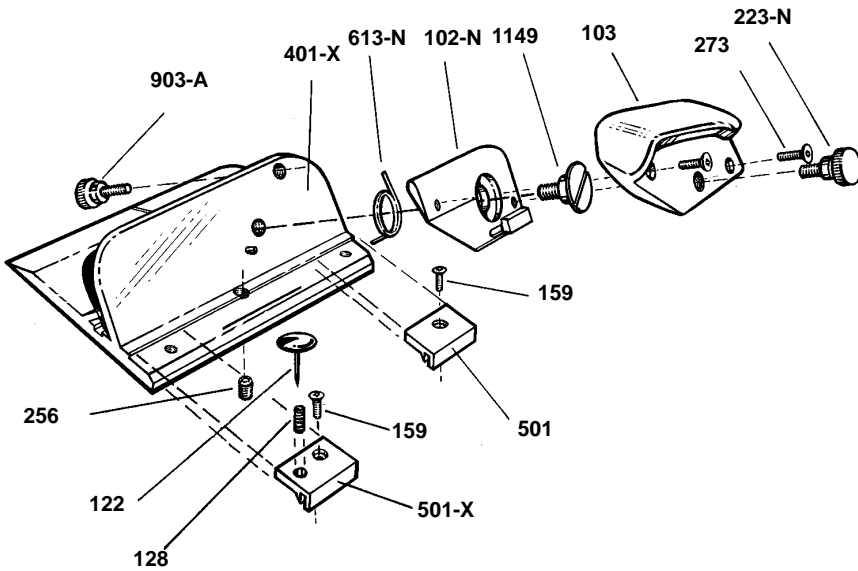

### 702 Bevel Cutting Head

903-A	Retaining Screw
401-X	Simplex Cutter Base
613-N	Torsion Spring
102-N	Bevel Blade Holder
1149	Shoulder Screw
103	Bevel Blade Cover
273	Blade Cover Screw x 2
223-N	Blade Holding Screw
501	Bearing
501-X	Bearing
128	Spring
122	Anti-Crawl Pin
256	Blade Depth Screw
159	Bearing Screw x 2

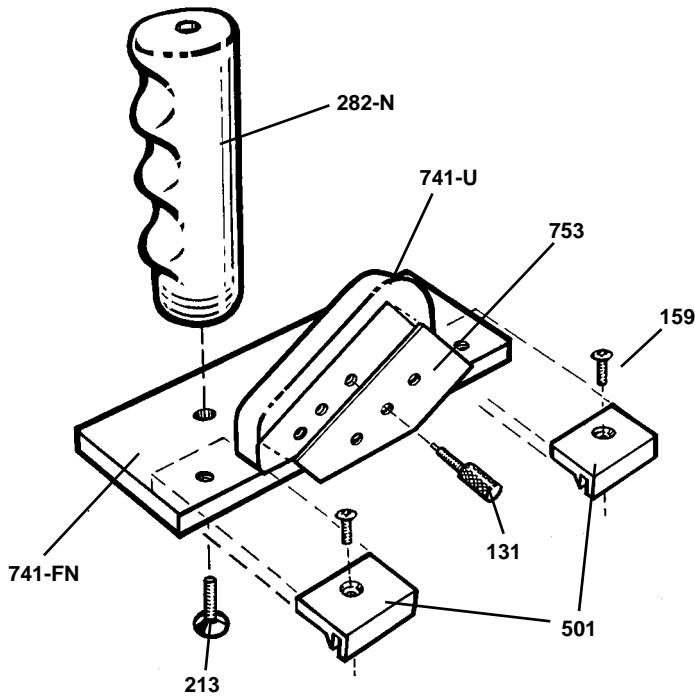

### 701 Straight Cutting Head

282-N	Handle
741-U	Upright Base
753	Blade Cover
159	Bearing Screw x 2
131	Knurled Screw
501	Bearing x2
213	Screw
741-FN	Straight Cut Base

# #401 Intermediate B. Base Board

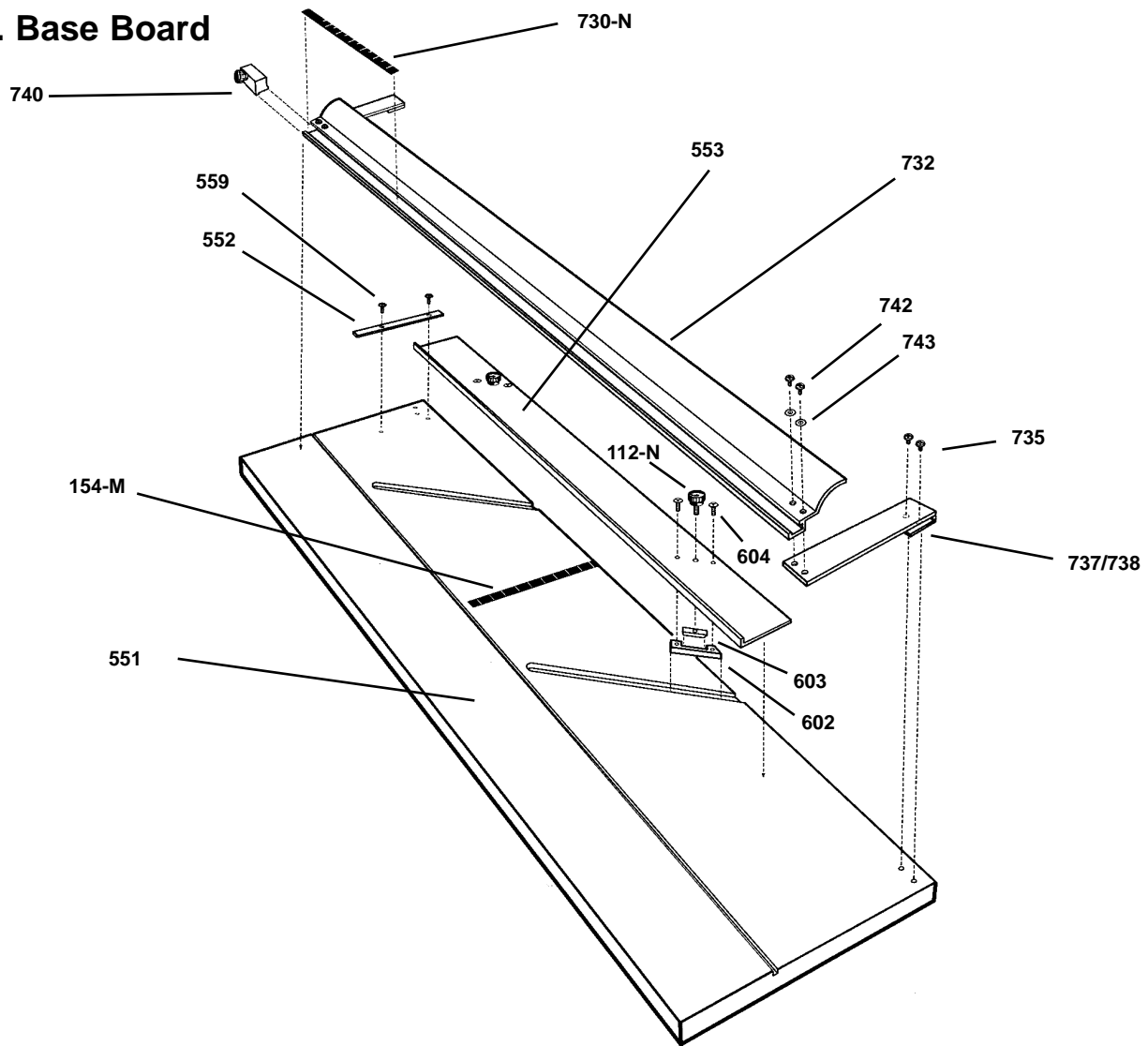

#401 Intermediate Base Board	
551	Base Board
112N	Mat Guide Screws x 2
604	Screws x 4
602	Slide x 2
603	Wedge x 2
559	Screw x 2
229	Feet <i>not shown</i>
737/738	Hinges x 2
743	Washers x 4
742	Screws x 4
154-M	Mat Guide Scale
553	Mat Guide
552	Squaring Bar
735	Woodscrews x 4
740	Production Stop
730-N	Stop Scale
732	Guide Rail

# Trouble Shooting

<b>Problem</b>	<b>Solution</b>
Hooks or Curves	<p>Blade depth set too deep. (see page 6)</p> <p>Blade is dull.</p> <p>Blade is catching on previous cut in Backing Sheet. (see page 3)</p> <p>Uneven pressure being applied to Cutting Head during cut. (see page 5)</p>
Overcut on Top Cut	<p>Cutting Head crawling forward as you insert the blade. Use Anti-Crawl Pin (see page 5)</p> <p>Blade depth set too deep. (see page 6)</p>
Overcut on Bottom Cut	<p>Adjust where you start and stop in relation to Start and Stop indicator.</p>
Mat Borders Uneven	<p>Not keeping mat squarely against Squaring Bar when cutting. (see page 4)</p> <p>Mat Guide not parallel (see page 7)</p>
Ragged Bevel Cut	<p>Cutting without a Backing Sheet (see page 3)</p> <p>Backing Sheet is worn out. (see page 3)</p> <p>Not changing the blade often enough.</p>
Not Cutting Through	<p>Machine not on a level surface (see page 8)</p> <p>Not using a Backing Sheet as least as long as the mat you are cutting. (see page 3)</p> <p>Backing Sheet not as wide as Guide Rail.</p> <p>Blade depth set to shallow. (see page 6)</p>

# Creative Matting Guide

Detailed Instructions on how to cut more creative style mats.

Including: The Double Mat  
The Off-set Corner Mat  
The Inlay Mat



# CREATIVE MATTING GUIDE

## A. DOUBLE RECTANGLE MAT

(Example 8' x 10" w/3 1/2" x 5 1/2" opening)

**Step 1:** Set the Mat Guide to 2" and cut an opening in the mat from the BACK.

**Step 2:** Keeping the fallout piece in place, run double sided tape around the back of the window border. Do not put tape on cut line. Also put a small swatch of tape in the center of the fallout.

**Step 3:** Straight cut a second piece of matboard of a different color to an outside dimension 7 1/2" x 9 1/2".

**Step 4:** Affix the second mat FACE DOWN to the taped back of the first mat being sure it is centered reasonably well.

**Step 5:** Set the Mat Guide to 2 1/4" and cut the second opening. The double fallout will drop from the window and the mat will be finished and perfectly aligned. NOTE: Triple mats can be achieved by repeating the above procedures again.

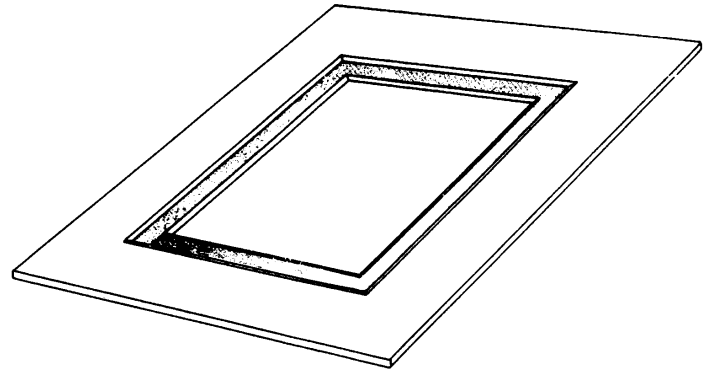

Double Mat

## B. OFF-SET CORNER MAT

(EXAMPLE: 8" x 10" w/ 7" x 5" opening)

**Step 1:** Set the mat guide at 2" and draw all four lines.

**Step 2:** Reset the Mat Guide at 1 1/2" and draw another set of lines.

**Step 3:** Leaving the Mat Guide at 1 1/2", place the mat in the cutter, put on the Bevel Cutting Head and line up the silver indicator line with the bottom pencil line closest to center of the mat. Cut until the silver indicator lines up with the top pencil line closest to the center of the mat. Using the same procedure, cut all four sides. IMPORTANT: At this point the fallout will not drop from the window. Continue.

**Step 4:** Remove the mat and reset the Mat Guide to 2". Reinsert the mat.

**Step 5:** Line up the silver indicator line on the Bevel Cutting Head with the drawn pencil line furthest from the center of the mat. Cut until the silver indicator line lines up with the line at the top of the mat furthest from the center of the mat. Using the same procedure, cut all four sides. NOTE: Be careful to hold the fallout piece in place as you turn the mat for the last cut.

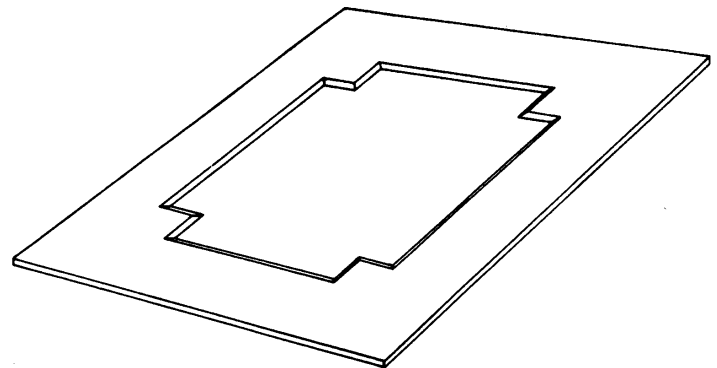

Off-Set Corner Mat

## C. Inlay Mat

Example 8" x10" w/7x5 opening.

**Step 1:** Set the Mat Guide at 2" and cut as per regular instructions.

**Step 2:** reset the Mat Guide at 1 1/2". Keeping the fallout in place, cut the mat again as per regular instructions. You may keep the fallout piece in place by taping it on the back.

**Step 3:** Discard the outer border piece and fallout. Retain the inside border cutout.

**Step 4:** Leaving the Mat Guide in place at 1 1/2", cut a second mat of a different color as per regular procedures. **IMPORTANT:** The second mat must be of the exact same outside dimension as the first mat.

**Step 5:** Remove the fallout piece from the second mat and place the inside border cutout from the first mat in the window opening from the second mat. The two pieces should fit together like a puzzle creating a flush surface across the front of the mat. Put tape on back to hold it in place.

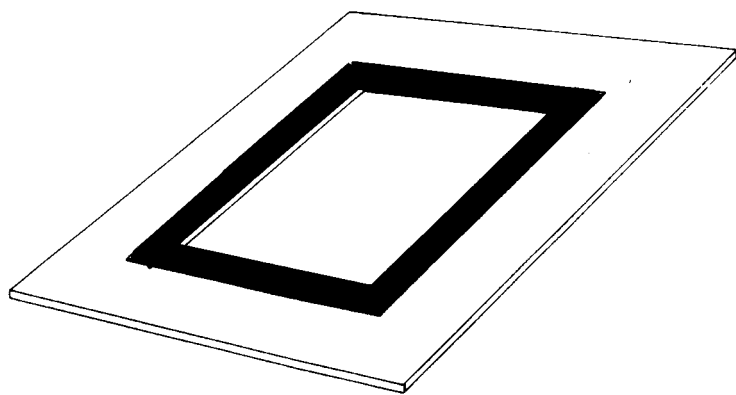

Inlay Corner Mat

**For more creative ideas in matting, pick up a copy of Logan's "How To Cut Mats" Video by Vivian C. Kistler, CPF. Item #237. Also available are 3 different books on matting and framing also by Vivian C. Kistler, CPF**

**Available through Logan dealers**



**#237 How To Cut Mats Video 35 min**

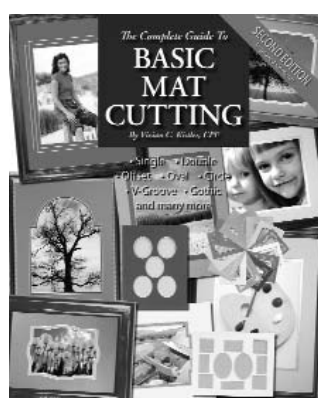

**#238 Basic Mat Cutting Book 65 pages**

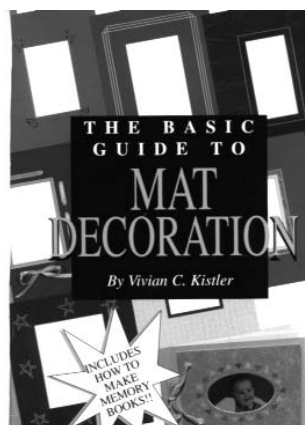

**#240 Mat Decoration Book 65 pages**

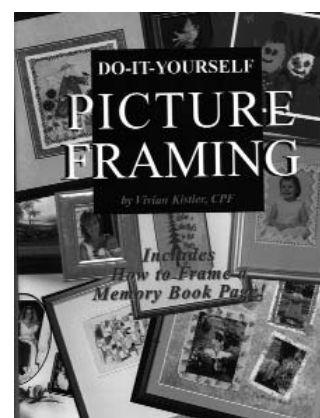

**#241 Do It Yourself Picture Framing Book 65 pages**

# Other Great Logan Products,

**Basic Mat Cutting Book** by Vivian C. Kistler, cpf. 64 pages of easy to understand instruction. Includes sections on color choice, layout and design. Or try the *How To Cut Mats Video*. 35 minutes long hosted by Vivian C. Kistler, cpf. VHS Format.

**Basic Mat Cutting-Item #238**  
**How To Cut Mats- Item #237**

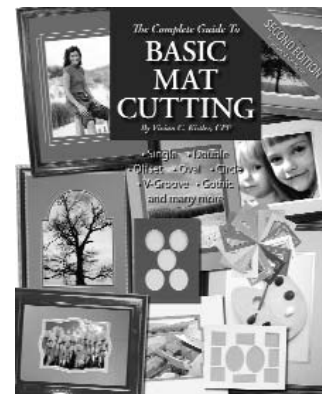

**Logan Glass Cutter** Simple and easy to use, this handy tool provides the ability to cut glass for framing right on your #401 Intermediate. Uses a hardened steel wheel and cuts glass up to .090" thick/ Uses replacement wheels #786.

**Glass Cutter-Item #704**  
**Replacement Wheels-Item #786**

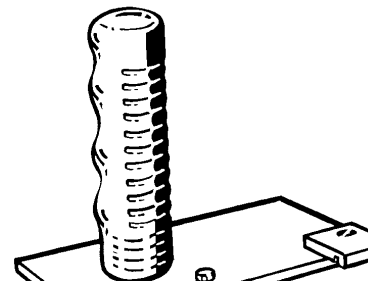

**Simplex Surface V-Groover** Offers a way to cut surface V-Grooves quickly and accurately with zero overcuts. Push-Pull action cuts V-Grooves right on the surface of the matboard eliminating any need for trimming or taping. Works entirely with stops. Uses Logan #1258 blades. #303 Compact V-Groove Adapter Stop needed to successfully operate Simplex V-Groover on any Logan #301 Compact or #401 Intermediate.

**Simplex V-Groover-Item #703**  
**Replacement Blades-Item #1258**  
**Compact V-Groove Adapter-Item #303**

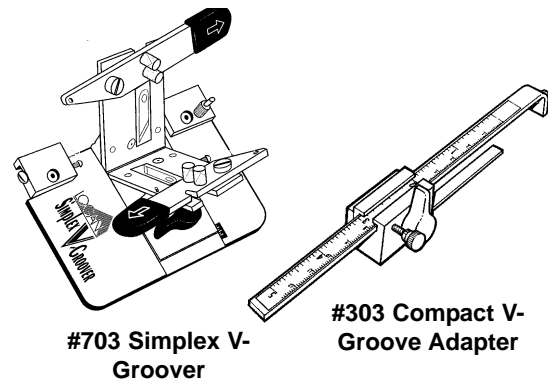

**3-Step Oval and Circle Mat Cutter** Easy to use, fast and portable. Cuts ovals or circles on the surface of the matboard using a patented 3-step mechanism for gradual increase of blade depth. Converts from oval to circle cutter with a turn of a knob. Ovals from 3 1/4" x 4 3/4" to 20" x 23". Circles from 4 1/2" to 20". Uses common blade. Logan #324, Dexter or X-acto equivalent.

**3-Step Oval and Circle Matcutter-Item #201**  
**Replacement blades #324**

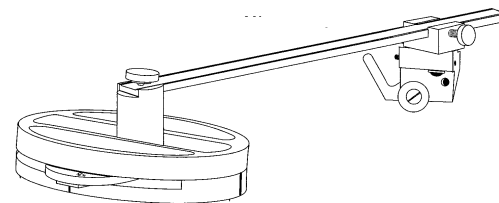

**See Your Local Logan Dealer For Availability Or Call Logan At 800/331-6232 For A Dealer Near You**



**Logan Graphic Products, Inc.**  
1100 Brown Street  
Wauconda, IL 60084  
847/526-5515 fax 847-526-5155  
toll free 800/331-6232  
www.logangraphic.com

**L558**  
**08/02**