

GENERAL PURPOSE TRIMMER

TOTAL TRIMMER

Introduction

The Logan Trimmer offers many unique features and durability that make it the best value trimmer/cutter available. Capable of handling your most demanding trimming needs, the Total Trimmer is the versatile work-horse trimmer you have been looking for. Ideal for trimming difficult materials like PVC foamboard and vinyl, it also easily cuts common materials such as films, paper and almost any flexible or rigid materials. Easy to use, ergonomic design, safety features and inexpensive cost makes the Total Trimmer a cutter with great features at a great price.

For advice, assistance or replacement parts please contact us at www.logangraphic.com

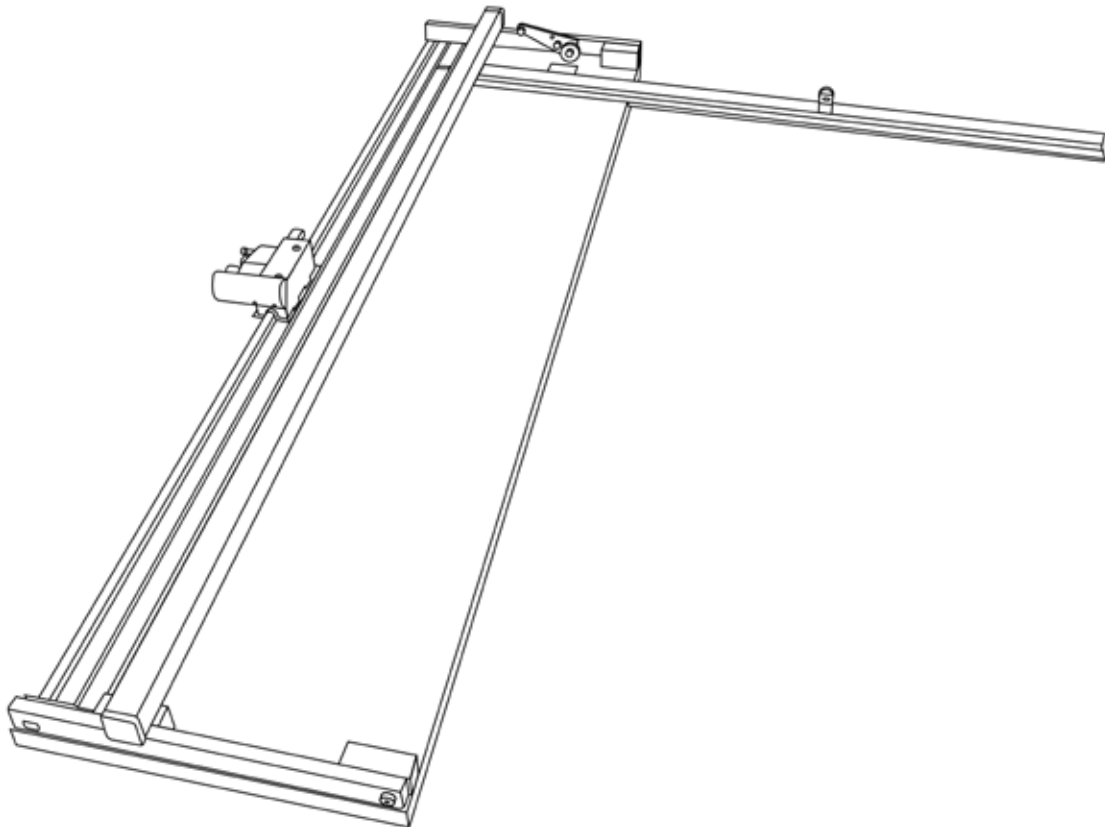

For best results use only
authentic Logan blades

Identification

Board

- A. Squaring Arm
- B. Squaring Arm Stop
- C. Lifter
- D. Cutting Head
- E. Cutting Bar
- F. Handle Bar

Head

- G. Blade Knob
- H. Depth Adjustment Knob
- I. Plunger Pin
- J. Blade Holder

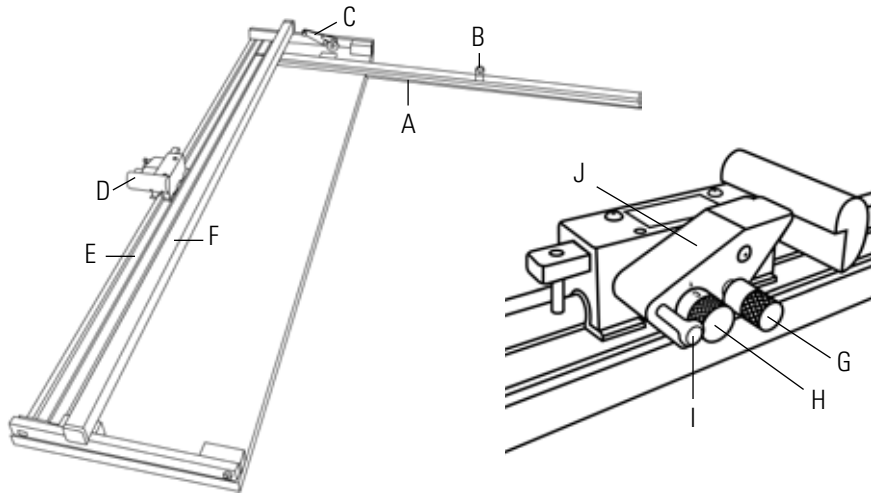

Safety

- Remove blades when servicing machine.
- Do not place your fingers near blade when using machine.
- Be sure lifter bar is down when cutting.
- Do not force cutting head if stuck.

Assembly

Attaching Squaring Arm & Stop

1. Use two screws to attach squaring arm to board.
2. Slide stop on to squaring arm. (Fig. 1)

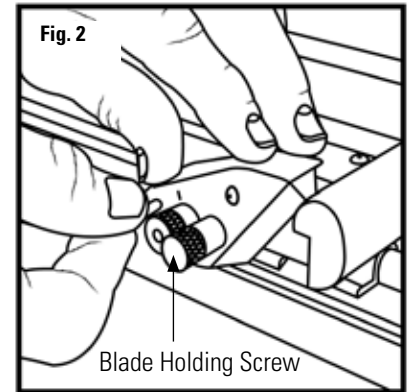
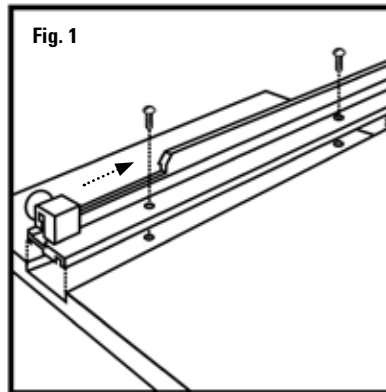

Blade Installation

1. With handle bar in down position, pull out plunger pin & rotate blade holder back. Loosen blade holding screw (Fig. 2)
2. Slide blade into slot under "Blade" label. (Fig. 3)
3. Tighten screw & rotate blade holder back until plunger pin releases to safety position.

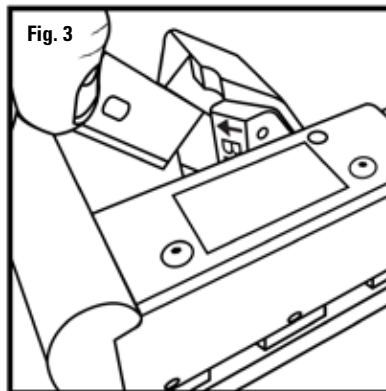
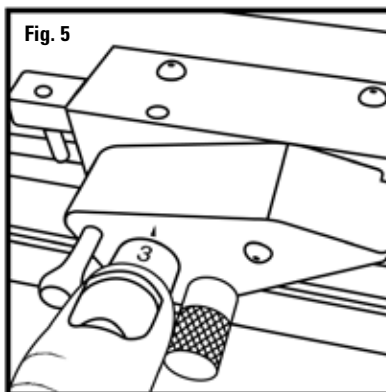

Fig. 4

BLADE DEPTH SETTINGS	
1 1/8"	3mm
2 3/16 - 1/4"	5-6mm
3 3/8 - 1/2"	9-12mm
Use Blade#267	

Depth Setting

1. Determine desired depth setting using Blade Depth Settings chart. (Fig. 4)
2. Rotate depth adjustment knob to desired number setting. (Fig. 5)



Operation

1. Raise cutting bar using lifter arm or raise to full open position. (Fig. 6)
2. Slide material onto board and against squaring arm. (Fig. 7)
3. Adjust Stop to desired dimension. (Fig. 8)
4. Lower Cutting Bar
5. Slide Cutting Head beyond end of material.
6. Pivot blade down fully until it locks. (Fig. 9)
7. Place hand on to cutting handle & pull cutting head down through material until head reaches support bar. (Fig 10)
8. Upon contact with support bar, the blade holder will automatically release to safety position. (Fig. 11)

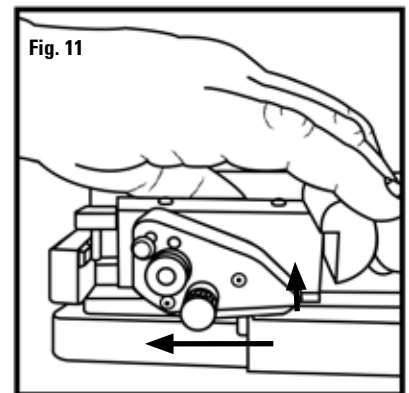
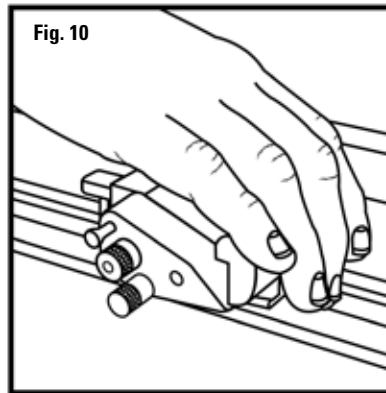
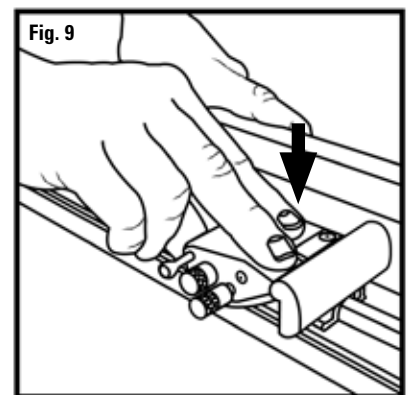
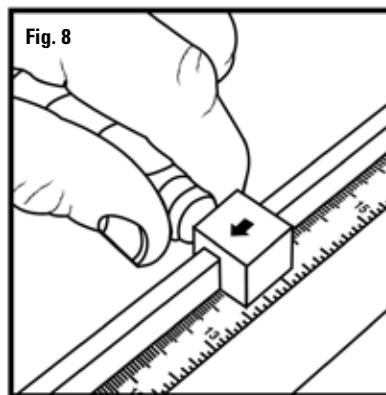
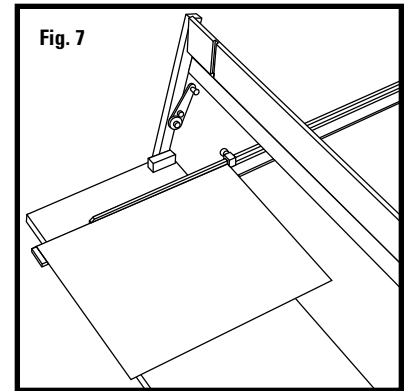
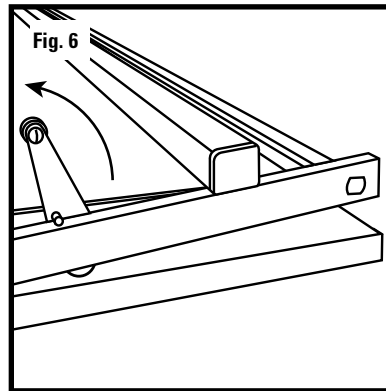

Maintenance and Adjustment

Cutting Head Bearings

If cutting head is loose or wobbling, tighten three adjustment screws to eliminate the play and improve cut accuracy. (Fig. 12)

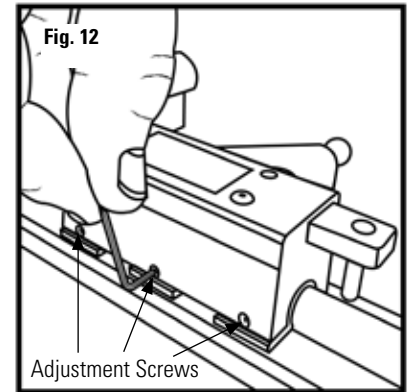

Resquare Squaring Arm

1. Place a carpenter's square against cutting bar first. Slide against squaring arm and look for gaps between square and squaring arm. (Fig. 13)
2. Notice which way squaring arm would have to move to eliminate gap.
3. Remove squaring arm and locate two screws inside side slots. (Fig. 14)
4. To adjust, move each screw equal but opposite directions. Only adjust a small amount.

DO NOT ADJUST TENSION SCREW - Single screw on opposite side

5. Retest squareness.

