

# INSTRUCTION AND OPERATION MANUAL

24" Guiderule, Bevel Cutter, Mat Knife, Blades, Matboards, Rub-on Transfers and Basic Mat Cutting Book.

# DO-IT-YOURSELF MAT CUTTING KIT

## MODEL 525



**Logan Graphic Products, Inc.**  
1100 Brown St. Wauconda, IL 60084 USA  
Phone (847) 526-5515  
Fax (847) 526-5155  
Toll Free (800) 331-6232  
cs@logangraphic.com

**LoganGraphic.com**

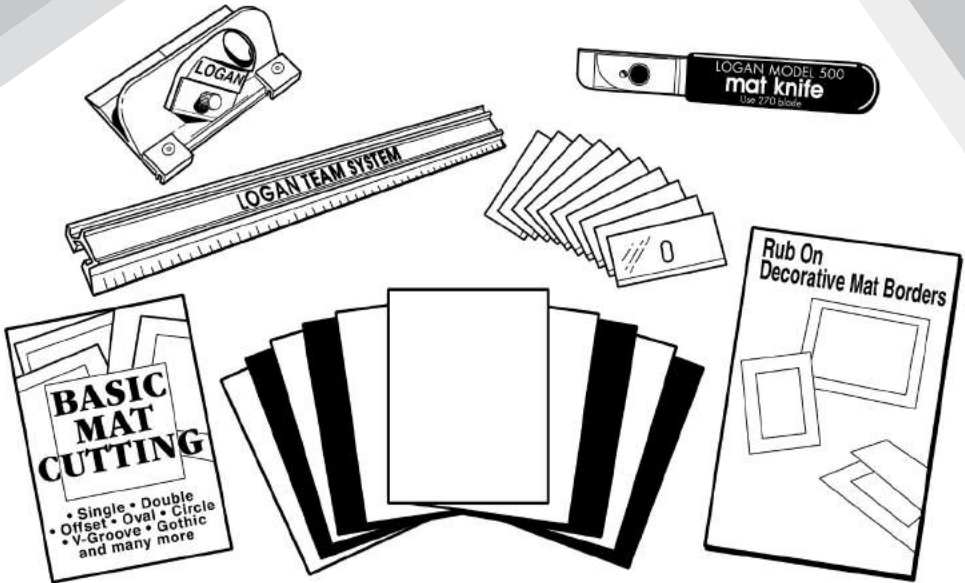

**For best results use only authentic Logan blades**



**CAUTION!!  
MAT CUTTING BLADES ARE SHARP**

Purchase Date \_\_\_\_\_

**DO-IT-YOURSELF MAT CUTTING KIT****MODEL 525****Preparation****Caution!! Mat Cutting Blades are Sharp****Inserting Blades****1. Mat Knife**

Remove one blade from pack of 5. Remove nut and Cover Plate. Align blade hole over thread. Be sure sharp edge of blade is facing downward. Reassemble Cover Plate. Adjust blade to one of three settings: Double thick mat board/foam board (fully extended), standard (middle setting) or safety setting (fully retracted). Tighten nut to lock in place.

**2. Bevel Cutter**

Remove the Blade Holding Screw from the front of the Bevel Cutter. Remove one blade from the package of 5. Slide the blade down onto the FRONT of the chrome Blade Holder. (Sharp edge down) until the bottom right hand corner of the blade enters into the Blade Slot and the hole in the blade lines up with the hole in the chrome Blade Holder. Replace Blade Holding Screw in hole and re-tighten.

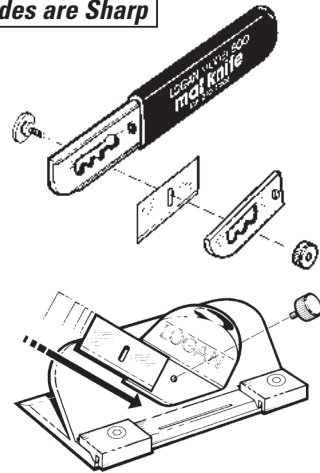
**Operation****Mat Knife****Cutting a Board to Size**

The Mat Knife is used for trimming matboard or foamboard to size for the outside dimensions. The Straight Edge has three settings: Double thick mat board/foam board (fully extended), standard (middle setting) or safety setting (fully retracted).

**1. Use a Slip Sheet**

Before cutting, be sure to use a slip sheet of scrap matboard the same size or larger than the piece you are going to cut underneath the matboard you will be cutting. For now use one of the 10 pieces provided in the box. The slip sheet provides a place for the blade tip to go so it won't cut into the surface you are cutting on and also helps stabilize the blade to get nice straight cuts.

**2. Measuring**

Draw pencil lines on back of matboard at desired size. Place the channel side of the rail edge along the left side of the pencil line. **Fig 1**

**3. Precut**

Hold the rail firmly in place with your left hand. With your right hand hold the Mat Knife vertical so that the handle is at a 45 degree angle putting the tip against the Straight Edge. **Fig 2.**

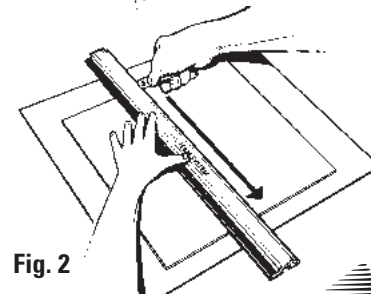
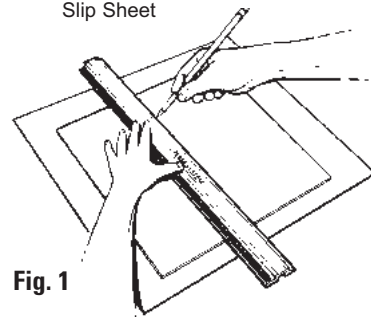
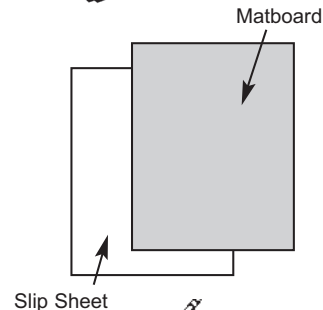

**DO-IT-YOURSELF MAT CUTTING KIT****MODEL 525**

If you are cutting across a sheet of matboard, simply start the blade beyond the top edge of the board and pull the Mat Knife completely through.

**4. Cutting**

Draw the Mat Knife toward you along the Straight Edge keeping constant pressure on the Straight Edge and downward pressure on the Mat Knife. **Fig. 3.**

**WARNING! Be careful when knife reaches the end of the mat so that it does not "jump" toward you.**

**Bevel Cutter****Cutting a Single Mat**

1. Using the scale side of Straight Edge, mark the back of the mat for the exact border you want.
2. Place the mat face down on the Slip Sheet. Place the Straight Edge EXACTLY on the left hand border so that the outside edge of the channel is lined up along the pencil line. **Fig.4.** Make sure that the bulk of the mat is to the right hand side of the Straight Edge. Having the mat on the left side of the Straight Edge will result in a reversed bevel cut. Attach the 302 Bevel Cutter to the straight edge by fitting the black nylon guides over the raised edge of the channel. Position the Mat Cutter so that the silver indicator line lines up with the bottom intersecting pencil line. **Fig.5**
3. Hold downward pressure on the Straight Edge with your left hand. Place the thumb of your right hand on the thumb divot on the retractable Blade Holder and plunge the blade into the mat.
4. Keeping downward pressure on the Blade Holder, slide the Bevel Cutter away from you until the silver line on it intersects with the upper pencil line. Be sure to keep even downward pressure. **Fig. 6**
5. Use your thumb to pull the Blade Holder back into the up position so the blade is removed from the mat. Repeat these steps for the remaining three sides. Congratulations! You have just cut your first mat.

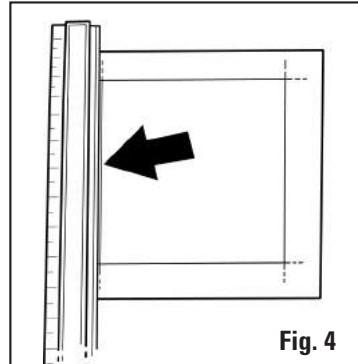
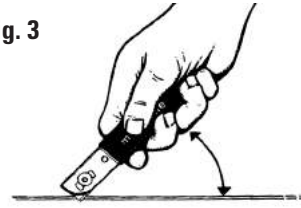
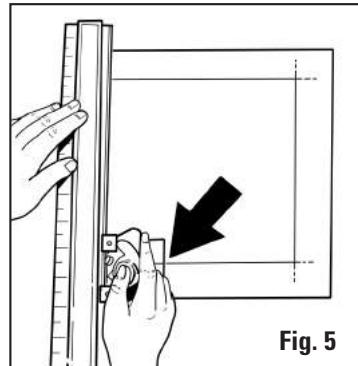
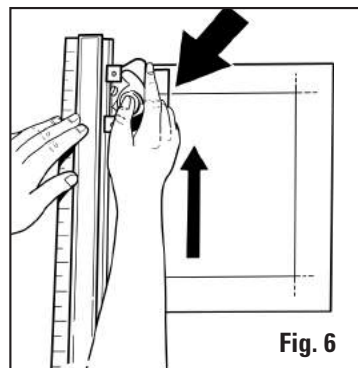
**Fig. 3****Fig. 4****Fig. 5****Fig. 6**

**DO-IT-YOURSELF MAT CUTTING KIT****MODEL 525****Apply Rub-on Transfers**

Align the sheet of transfers across the top of the mat with desired design in place. Use the grid on the sheet to aid in alignment. Using any smooth blunt object (blunt tipped pencil, spoon handle, coin, etc.) gently rub on the back of transfer sheet to apply transfer on the surface of the matboard.

**Trouble Shooting****Bevel Cut has a Rough Edge**

1. You may need to change your blade more often. Dull blades drag through the mat instead of cut.
2. Change your Slip Sheet. Cutting over the same area on the Slip Sheet repeatedly can cause rough cuts.

**Not Cutting Through the Mat**

1. Keep even downward pressure on the Chrome Blade Holder throughout the cut. Letting pressure off will allow the blade to come out of the mat.
2. Check your blade depth. Insufficient blade depth can result in undercut mats. To adjust the blade depth on the Bevel Cutter, turn the screw on the underside of the cutting head clockwise to decrease or counter-clockwise to increase the amount of the exposed blade.

**Overcuts In Corners**

1. Check your blade depth. Extra blade depth can cause the blade tip to cut past the marked lines producing an overcut. Using the recessed screw on the bottom of the Bevel Cutter, adjust the blade tip to allow for 1/8" exposure. The blade should just score into the surface of the Slip Sheet. To adjust the blade depth on the Bevel Cutter, turn the screw on the underside of the cutting head clockwise to decrease or counter-clockwise to increase the amount of the exposed blade.

**Hooks or Curves in Cut**

1. Check your blade depth. Extra blade depth can cause the blade tip to flare out producing a hook or curve. Using the recessed screw on the bottom of the Bevel Cutter, adjust the blade tip to allow for 1/8" exposure. The blade should just score into the surface of the Slip Sheet. To adjust the blade depth on the Bevel Cutter, turn the screw on the underside of the cutting head clockwise to decrease or counter-clockwise to increase the amount of the exposed blade.
2. Change the blade. A dull blade will flare out causing a hook or curve.  
A NOTE ON BLADES: No two blades will have the same lifespan. Always start with a new blade before each project to ensure best results.

**DO-IT-YOURSELF** **MAT CUTTING KIT** **MODEL 525**

**Warranty**

Logan Graphic Products, Inc. ("Logan") warrants the Do-It-Yourself Mat Cutting Kit Model 525 to be free from defects in parts and workmanship for a period of two years from the date of original purchase. Logan warrants that it will either repair or replace, in its sole discretion, any necessary replacement parts found to be defective. Should the product need to be returned to Logan for repair or replacement parts, authorization for any return must come from Logan in writing. Costs of returning the product to Logan, including insurances, shall be borne by the purchaser. Logan shall not be liable for any damages or losses, incidental or consequential, direct or indirect, arising from the use of this product. This warranty extends only to the original purchaser and is not assignable or transferable. This warranty is in lieu of all other warranties, expressed or implied. Be advised that any Logan products purchased as "new" from an unauthorized dealer, such as an online auction site or similar, may be void of their warranty.