

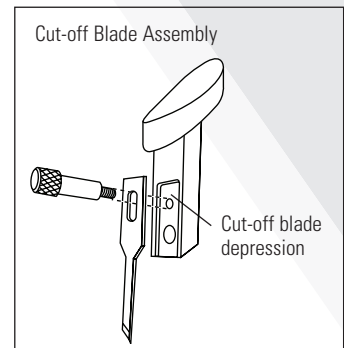

INSTRUCTION AND OPERATION MANUAL

Contents of the Model 707 Groovy Mouse Carton

- 1 Groovy Mouse
- 2 Quick Corner Marker
- 3 Two V-Groove blades
- 4 One Cut-off blade

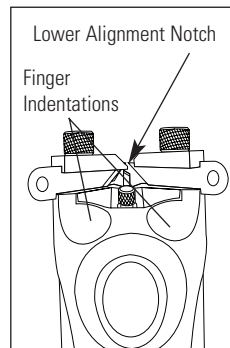
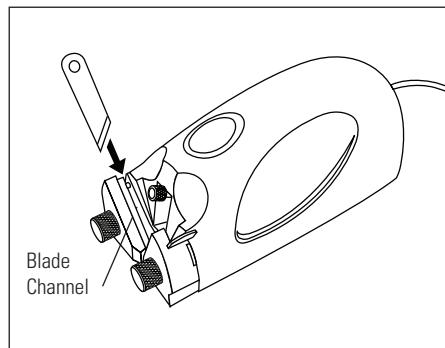
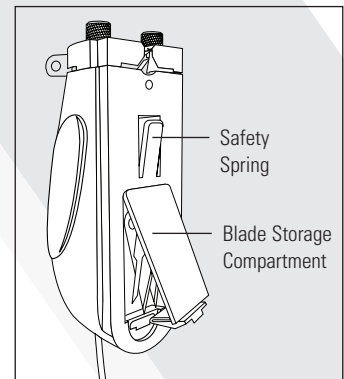
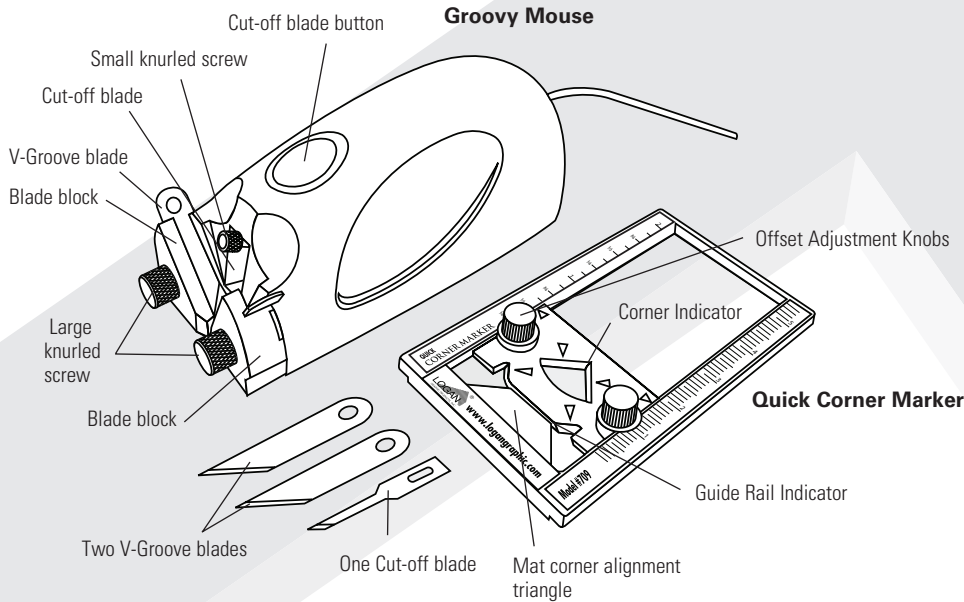

Warranty

Logan Graphic Products, Inc. ("Logan") warrants Groovy Mouse - Model 707, to be free from defects in parts and workmanship for a period of one year from the date of original purchase. Logan warrants that it will either repair or replace, at its sole discretion, any necessary replacement parts found to be defective. Should the product need to be returned to Logan for repair or replacement parts, authorization for any return must come from Logan in writing. Costs of returning the product to Logan, including insurances, shall be borne by the purchaser. Logan shall not be liable for any damages or losses, incidental or consequential, direct or indirect, arising from the use of this product. This warranty extends only to the original purchaser and is not assignable or transferable. This warranty is in lieu of all other warranties, expressed or implied.



www.logangraphic.com

Logan Graphic Products, Inc.
 1100 Brown Street
 Wauconda, IL 60084 USA
 Phone (847) 526-5515 Fax (847) 526-5155
 Toll Free (800) 331-6232
 Email - info@logangraphic.com

For best results use only authentic Logan blades

CAUTION: BLADES EXTREMELY SHARP

Use Logan replacement blade kit #326.

L1781 8/07

Installing Blades

Cut-off Blade

1. Depress the cut-off button. While continually depressing the button, remove the small knurled screw (Figure 1).
2. Release the cut-off button and slide the button and cut-off blade assembly upwards through the cutoff button opening. If necessary, use the screw head to nudge the blade assembly upwards. Place a blade in the cut-off blade depression, matching the blade angle with the diagram on the cut-off blade assembly cavity (Figure 2) (Figure 4).
3. Slide the cut-off blade assembly down through the cut-off button opening. While depressing the cut-off button, reattach the small knurled screw and tighten.

V-Groove Blades

1. Loosen two large knurled screws. Looking down at Groovy Mouse, slide the blade into the blade channel, with the blade point to the front. Repeat for second blade (Figure 3).
2. NOTE: Adjust blade tips so they just touch in the center (Figure 4). Squeeze the blade blocks together to help steady the blade position and provide finer control.

Using Groovy Mouse

Note: Groovy Mouse features a safety spring located on the bottom. This prevents the blades from gouging mat board or table surfaces when not in use. Downward pressure on Groovy Mouse will engage the blades with the surface. Make sure that surfaces are protected wherever Groovy Mouse is placed.

Traditional V-Groove

1. Use a pre-cut mat or cut the mat opening to the desired size.
2. Loosen the Offset Adjustment Knobs on the Quick Corner Marker and align the indicator arrows to the desired offset dimension (distance from mat opening to v-groove). Tighten the knobs to lock in place (Figure 5).
3. With the front of the mat facing up, place the mat alignment triangle located at the base of the Quick Corner Marker snugly into any corner of the mat. Make light pencil marks at the Guide Rail Indicator and Corner Indicator identified by the long arrowheads. Repeat for all four corners (Figures 6 & 7).
4. Align guide rail with short tick marks. Note that mat opening should slide underneath guide rail. Groovy Mouse can be used with any suitable straight edge or most Logan straight edges including Adapt-a-Rule, Team System plus Logan board mounted mat cutters Compact, Intermediate+ and Simplex Plus.
5. Hook Groovy Mouse on the guide rail. Align V-Groove blades with the upper corner indicated by pencil lines. Place index and middle finger tips into indentation areas, remaining fingers on rubber side grips (Figure 8). Push downward towards the front of Groovy Mouse and with steady pressure, pull the tool towards the lower corner mark.
6. While maintaining pressure, stop when the lower alignment notch located on the left blade channel reaches the lower corner pencil line. Lift index finger and depress the cut-off blade button. Release the cutoff blade button and continue to maintain even pressure while pulling Groovy Mouse slightly back to meet the cut. The V-Groove waste should now fall away (Figure 9).
7. Rotate the mat board 90° and repeat Steps 5 & 6 for the next two sides. For the final side, repeat Step 5 but pull Groovy Mouse into the previously cut corner. The waste should drop away.
8. Using an artist's eraser (kneaded, gum, etc) gently erase any pencil lines that remain on the mat surface.

Freestyle V-Groove

Groovy Mouse can also be used to cut freestyle V-Grooves. Please note the following for best results.

1. Lightly mark the desired design on the mat surface.
2. Practice on scrap mat board to determine best design and corner radius.
3. Keep even pressure on Groovy Mouse when blades are engaged.
4. Once complete, use an artist's eraser to gently erase any remaining pencil lines.

Freestyle Mat Opening

Groovy Mouse can also be used to cut freestyle beveled mat openings. Please note the following for best results.

1. Remove one V-Groove blade, and adjust the remaining blade to extend 1/8" below Groovy Mouse blade holder.
2. Lightly mark the desired opening with a pencil.
3. Use a backing sheet underneath the mat board.
4. Once complete, use an artist's eraser to gently erase any remaining pencil lines.

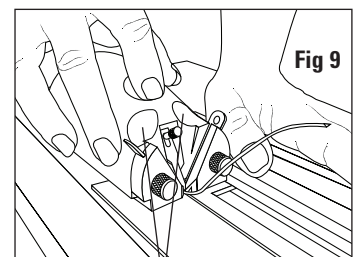
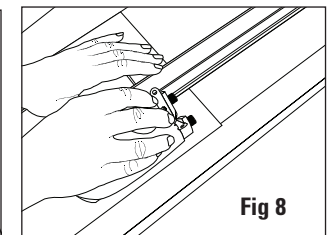
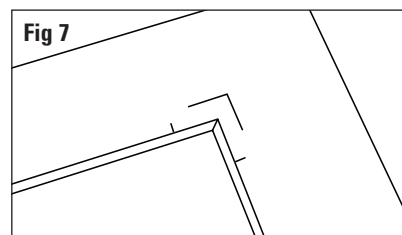
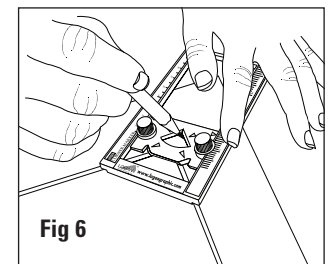
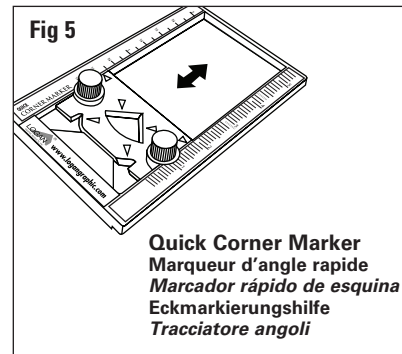
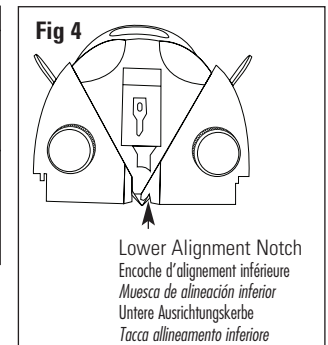
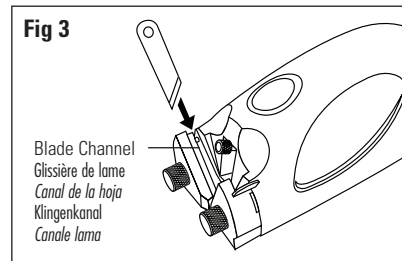
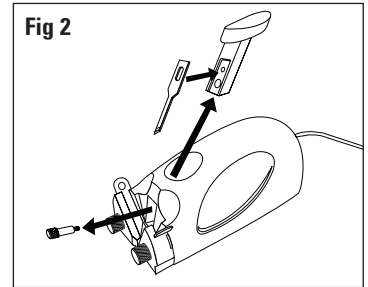
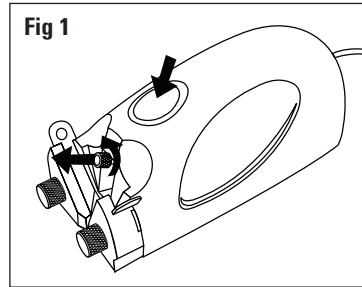

Finger Indentations

Trouble Shooting

V-Groove has a Rough Edge

1. The V-groove blades may be dull. Replace the blades.
2. The V-groove blades may need adjusting. Adjust the blade tips so they just meet in the center.

V-Groove is Cutting Through the Mat

1. Check the V-groove blade depth. Excess blade depth may cut through the mat board. Using the large knurled screws, adjust the blade tips to reduce the blade depth.

V-Groove depth is uneven

1. Maintain even pressure throughout the cut.