

SIMPLEX ELITE MAT CUTTER

INSTRUCTIONS AND OPERATION MANUAL

40 in (101 cm) mat cutting system with bevel & straight cutters, production stops, 32 in (81cm) squaring arm, 8-ply cutter, acrylic plastic cutter, glass cutter, paper trimmer and framing book.

For best results use only authentic Logan blades

Uses Logan Replacement
Blade #270 and
Blade #271 (8-Ply)

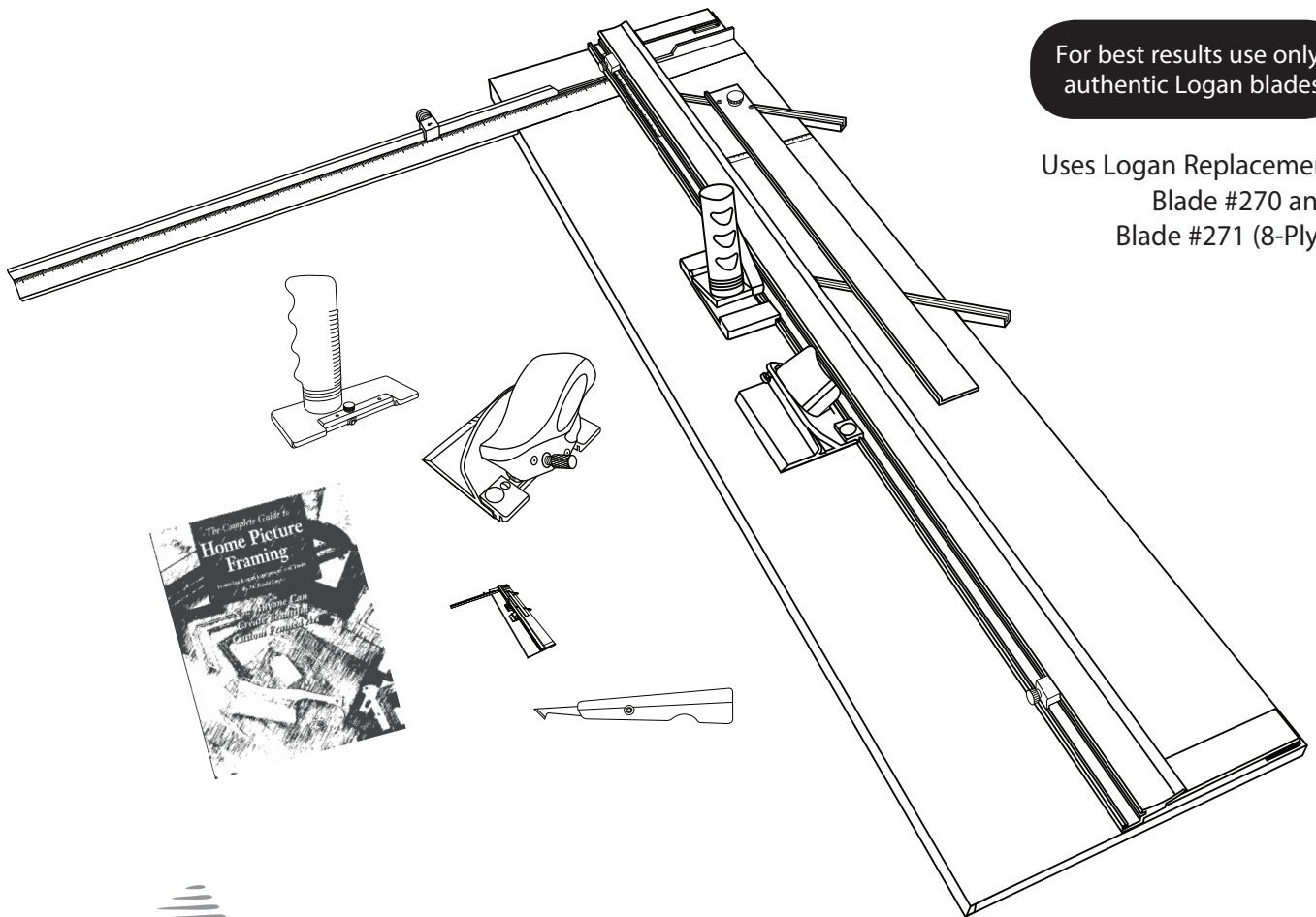

Purchase Date _____

ID Number (on bottom of board) _____

Date (on bottom of board) _____

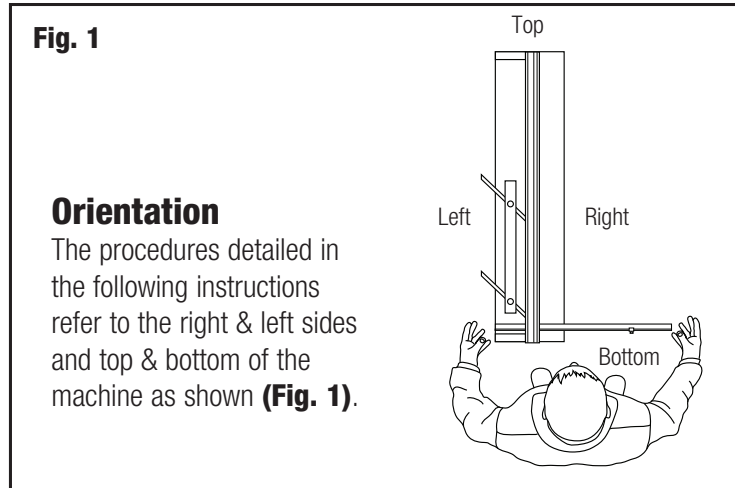

Carton Contents

1. Straight Cutter
2. Bevel Cutter
3. Squaring Arm
4. Squaring Arm Stop
5. Mat Guide
6. Mat Guide Channels (2)
7. Channel Screws (2)
8. Screwdriver
9. Rail Stops (2)
10. Blade Pack
11. Glass Cutter
12. Glass Cutting Oil
13. Acrylic Plastic Cutter
14. 8-Ply Cutter
15. 8-Ply Blades
16. Paper Trimmer

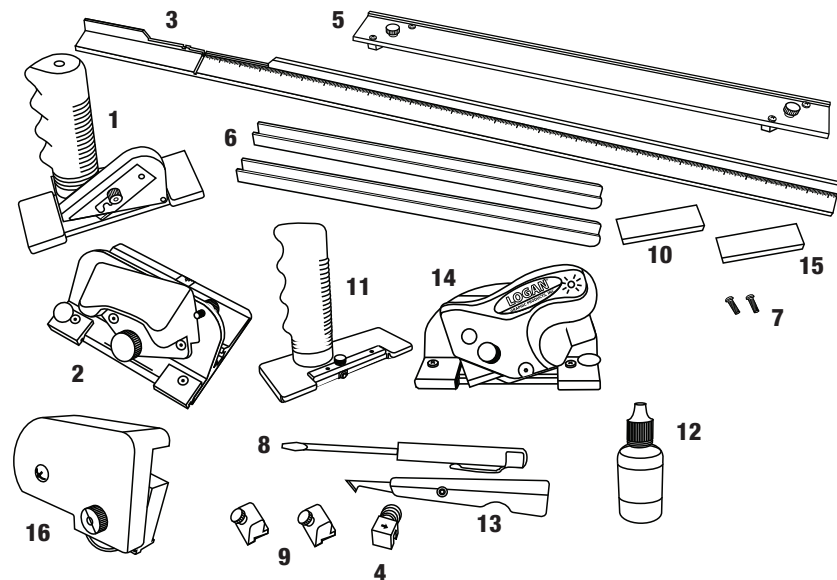

PRODUCT DESCRIPTION

The Simplex Elite is a well-designed mat cutter, combining the best of what Logan mat cutters have to offer. Features like heavy duty pull style bevel cutter with anti-crawl pin, pivot & pull straight cutter, production stops, squaring arm, parallel mat guide, 8-ply cutter with blades, acrylic plastic cutter, paper trimmer, glass cutter with oil and framing book make the Simplex Elite a cost effective and useful tool for artists, crafters, photographers and framers. This instruction manual is written to familiarize you with the product. Please take some time to review the instructions before cutting. You will find that the time taken will be well worth it, and you will be cutting professional mats in no time.

Identification of Machine Components

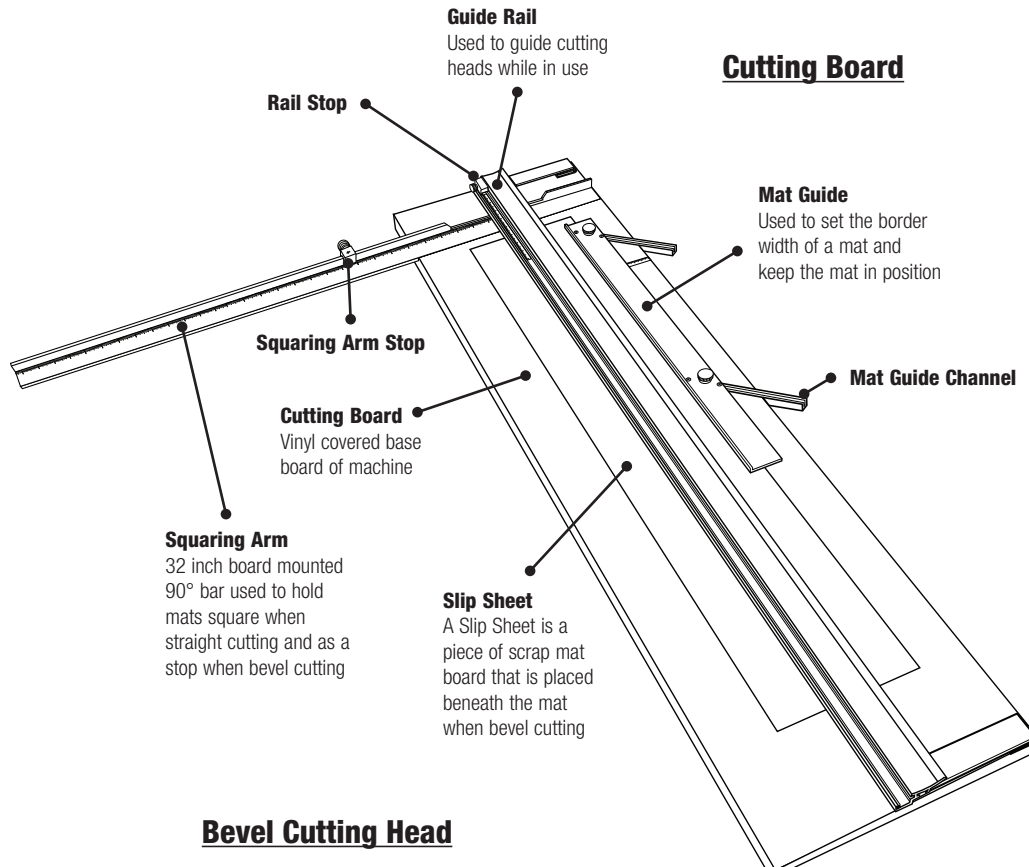

Bevel Cutting Head

Start and Stop Indicator

(not visible in this drawing - located on opposite side) Line which shows where to begin and end cut

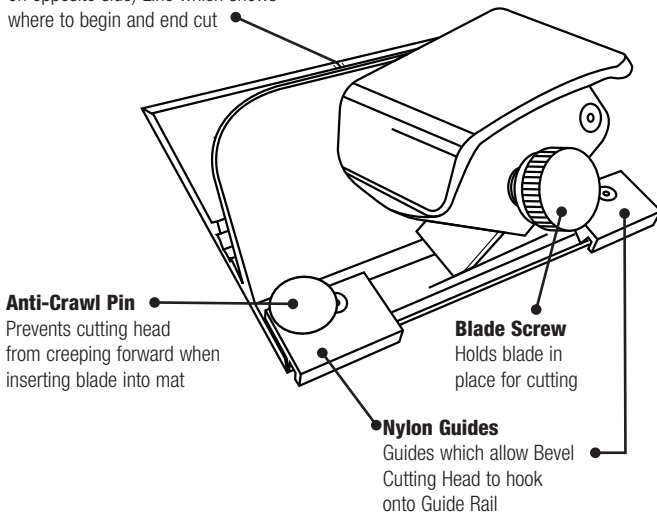

Straight Cutting Head

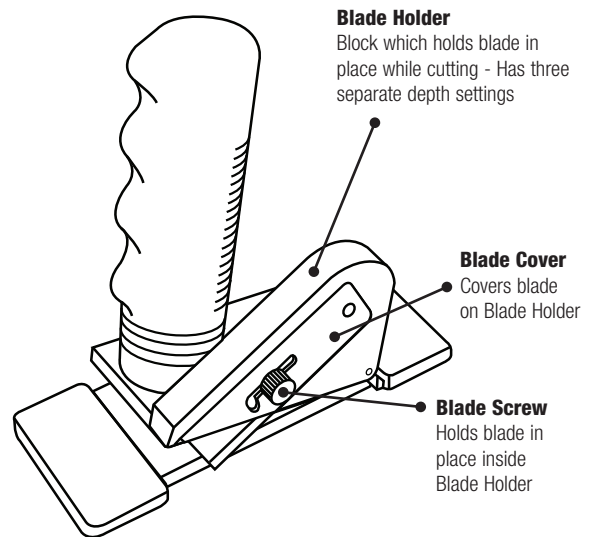

**CAUTION!!
MAT CUTTING BLADES ARE SHARP**

Set-Up



**CAUTION!!
MAT CUTTING BLADES ARE SHARP**

Blade Installation - Model 702-1 Bevel Cutter

1. Loosen blade retaining screw enough to allow blade holder to tilt back (**Fig. 2**). Loosen the blade holding knob.
2. Remove one blade from the package of five.

NOTE: Because the blades are packed with a small amount of oil, they may stick together. Be certain that only one blade is being inserted into the blade slot.

3. Slide blade, sharp edge down, fully into blade holder (**Fig. 3**).
- NOTE:** The hole in the blade is not designed to line up with the blade screw.
4. Tighten blade screw.
5. Tilt blade holder down, allowing tip of blade to enter into the blade slot and retighten retaining screw (**Fig. 4**).

Blade Installation - Model 701-1 Straight Cutter Elite

1. Remove blade knob and blade cover.
2. Align blade hole over thread. Be sure sharp edge of blade is facing down.
3. Reassemble blade cover and blade knob (**Fig. 5**).

NOTE: Adjust blade to foamboard (fully extended), standard 4-ply mat board (middle setting) or safety (fully retracted).

Mat Guide Assembly

1. Press each mat guide channel into board slots with rounded end towards guiderail. (**Fig. 6**).
2. Insert two channel screws from the UNDERSIDE of board and tighten (**Fig. 6**).
3. Loosen each mat guide knob three full turns.
4. Hold mat guide at ends with your thumbs on the loosened knobs with raised edge facing guiderail and evenly drop mat guide into channels.
5. Slide to adjust and tighten knobs to lock mat guide (**Fig. 7**).

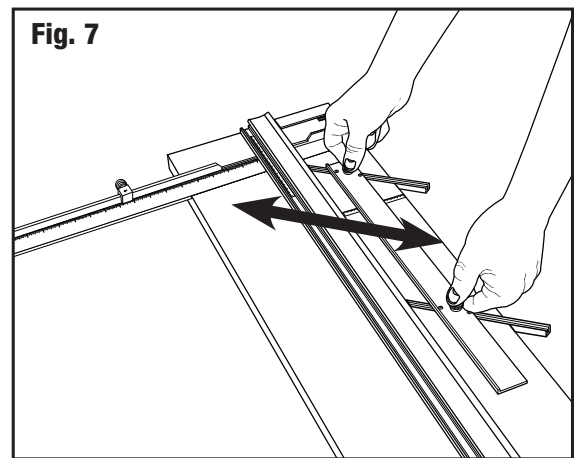
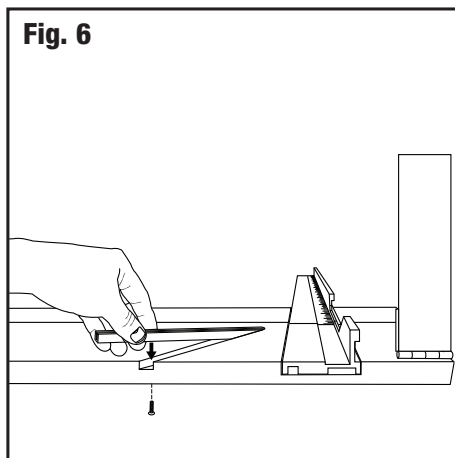
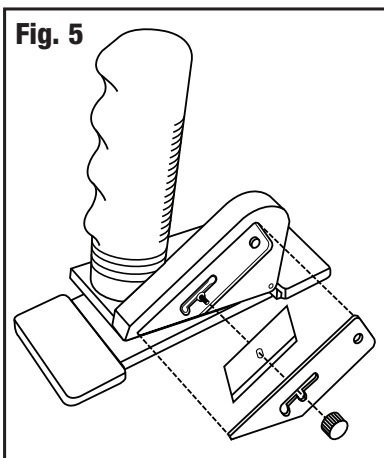
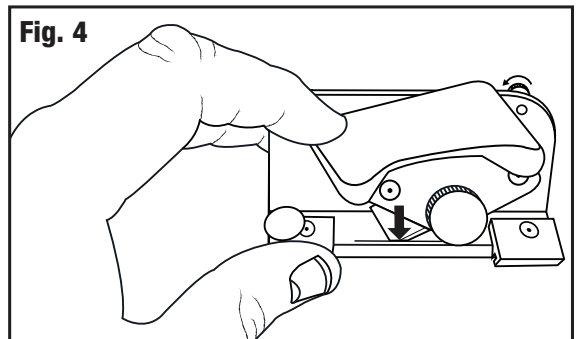
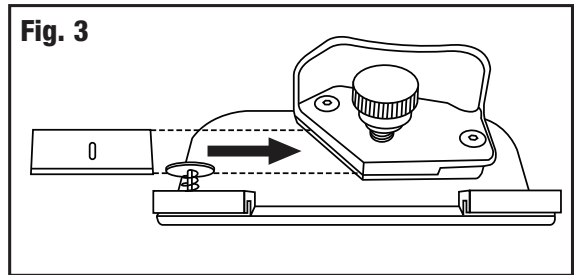
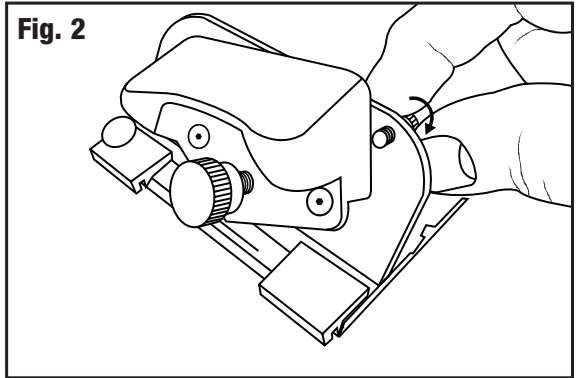

Squaring Arm Assembly

1. Line up squaring arm along side of slot, ensuring the bottom of the v-groove is underneath screw (Fig. 8).
2. Slide into the channel (Fig. 8).
3. Align slots and tighten screw (Fig. 9).
4. Slide stop onto squaring arm (Fig. 10).

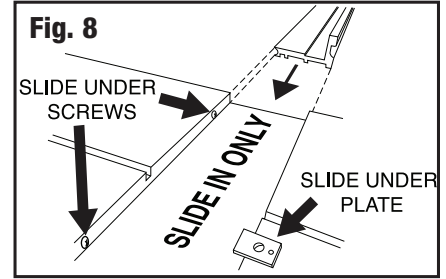

Straight Cutting Board to Size

1. Remove mat guide and slip sheet.
2. Set squaring arm stop to dimension of cut. Place mat (color side down) under guide rail and against squaring bar stop (Fig. 11).
3. Set the proper depth setting on the straight cutting head.
4. Hook the straight cutting head onto the guide rail past the end of the board to be cut. Grasp the handle as shown in the picture, pivot down and pull the straight cutting head towards you. Keep constant downward pressure on the straight cutting head and the guide rail as you make your cut (Fig. 12).

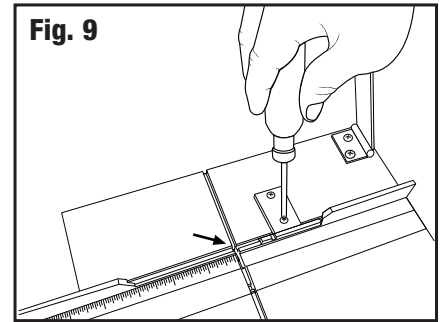

CAUTION: Be careful to control the straight cutting head as it breaks through the end of the matboard, as it will tend to “jump” towards you.

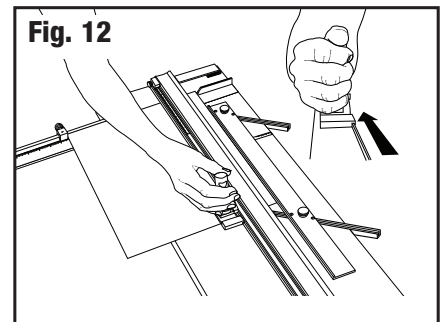
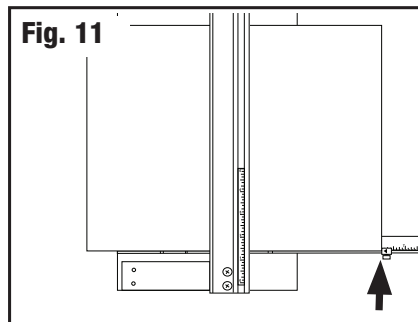
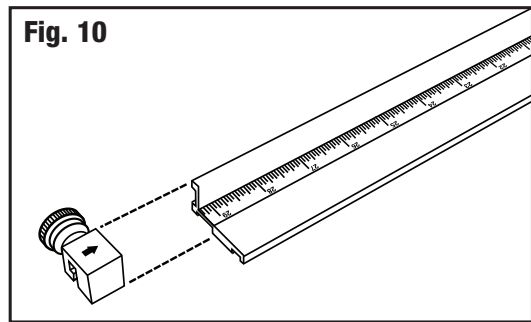

Bevel Cutting Mat Openings

Cutting Bevel Mats Using Line to Line Method

EXAMPLE: Cutting a mat with a 2” border.

1. Move stops out of cutting area or remove from rail (Fig. 13).
2. Set the mat guide to the desired border width. For example, for a 2” border, align the front of the mat guide at the 2” mark and tighten the black knobs (Fig. 14).
3. Make sure the slip sheet is in place before bevel cutting. You must use a slip sheet. The straight cut slot underneath the guide rail is for straight cutting only.

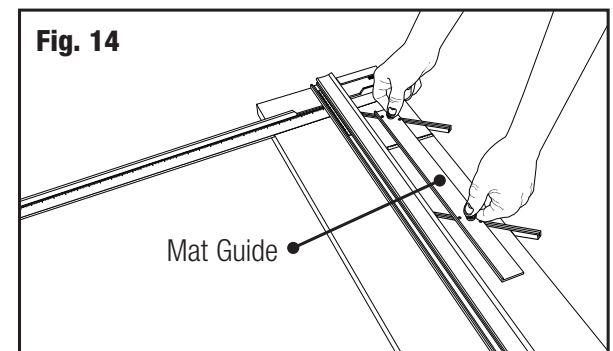
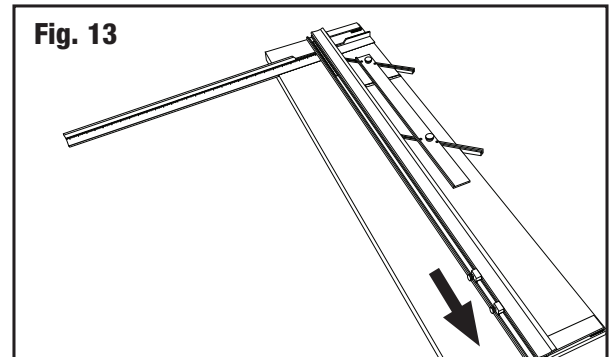

4. Place the mat color side down under the guide rail and up against the squaring bar and mat guide (**Fig. 15**).
5. Using a pencil, draw a line down the full length of the back of the matboard. Turn the mat after each marking and repeat this for the remaining three sides (**Fig. 16**).
6. Attach the 702-1 bevel cutter to the guide rail by fitting the black nylon guides over the raised edge of the channel.
7. Position the cutter so the start & stop line lines up with the marked line closest to the top of the machine (**Fig. 17**).
8. With left hand, depress the anti-crawl pin and firmly pivot the blade holder down into the mat (**Fig. 17**).
9. Release the anti-crawl pin and pull the cutting head towards you until start & stop line lines up with bottom pencil line (**Fig. 18**).

NOTE: It is essential to keep even downward pressure on the blade holder as you cut.

10. Rotate the blade holder back up to the neutral position, turn the mat 1/4 to the right. Complete this for the remaining three sides.

Bevel Cutting Mat Openings Using One Rail Stop

EXAMPLE: Cutting a mat with a 2" border.

1. Set the mat guide to the desired border width. For example, for a 2" border, align the front of the mat guide at the 2" mark and tighten the black knobs (**Fig. 14**).
2. Install or slide bottom rail stop over guiderail scale and set at 2" (**Fig. 19**).
3. Place the mat to be cut into the machine colored side down with the slip sheet underneath and lower the guide rail (**Fig. 15**).
4. Using a pencil, mark one line along the full length of the matboard using the guide rail as a guide (**Fig. 16**). Turn the mat 1/4 turn to the right before cutting.
5. Attach the 702-1 bevel cutter to the guide rail by fitting the black nylon guides over the raised edge of the channel.
6. Position the cutter so the start & stop line lines up with the marked line closest to the top of the machine (**Fig. 17**).

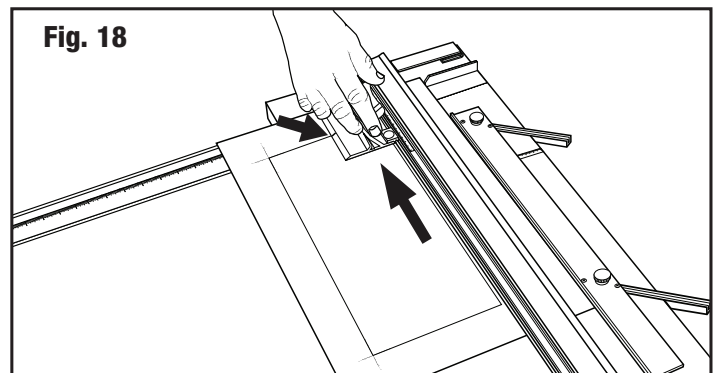
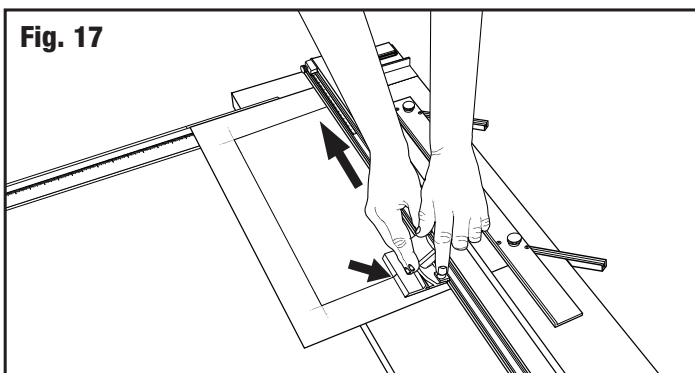
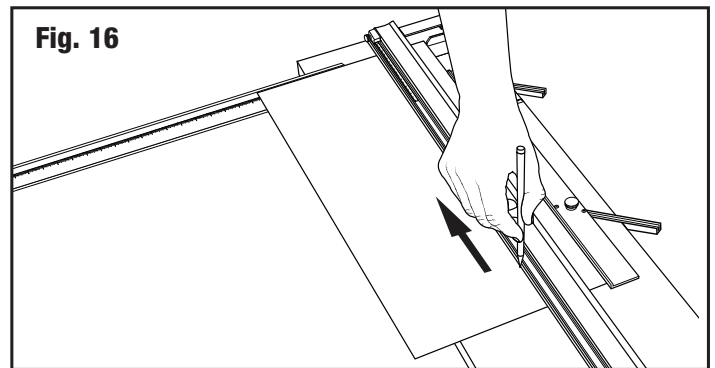
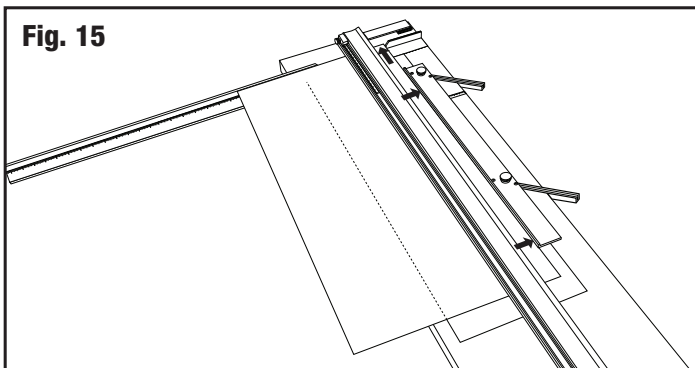

7. With left hand, depress the anti-crawl pin and firmly pivot the blade holder down into the mat (**Fig. 17**).
8. Release the anti-crawl pin and pull the cutting head towards you until you hit the stop (**Fig. 20**).

NOTE: It is essential to keep even downward pressure on the blade holder as you cut.

9. Rotate the blade holder back up to the neutral position, turn the mat 1/4 to the right and use the cut line in the back of the matboard to start your next cut. Complete this for remaining three sides.

Bevel Cutting Mat Openings Using Two Rail Stops (Production Cutting)

EXAMPLE: Cutting a mat with a 2" border.

NOTE: This method should only be used when cutting multiple numbers of mats that have the same outside and inside dimensions.

1. Set the mat guide to the desired border width. For example, for a 2" border, align the front of the mat guide at the 2" mark and tighten the black knobs (**Fig. 14**).
2. Place the mat to be cut into the machine colored side down with the slip sheet underneath and lower the guide rail (**Fig. 15**).
3. Using a pencil, mark a line along the full length of the matboard using the guide rail as a guide (**Fig. 16**). Turn the mat 1/4 turn to the right before cutting.
4. Install or slide the top guide rail stop onto the guide rail and slide it past the far end of the matboard but do not tighten it.
5. Install or slide the bottom guide rail stop onto the guide rail and tighten at the 2" mark on the guide rail scale (**Fig. 19**).
6. Hook the bevel cutting head onto the guide rail and slide up until the start & stop indicator lines up with the marked line closest to the top of the machine.
7. Slide the top guide rail stop towards you until it makes contact against the bevel cutting head and tighten (**Fig. 21**).
8. Both guide rail stops are now set to make repeated opposite side cuts on a multiple number of mats of the same size. To then cut the other side of the mats, reset the top stop as you did in step 6. and cut the remaining sides.

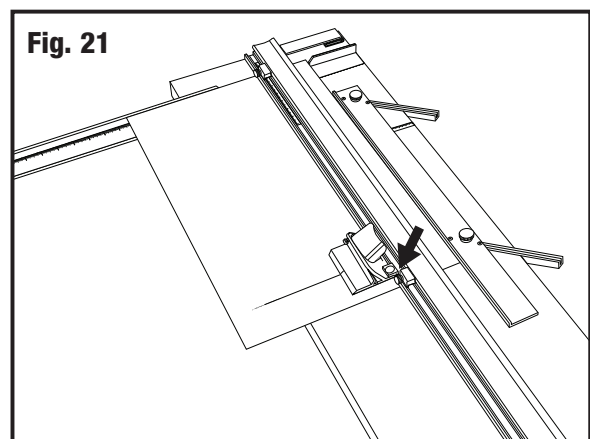
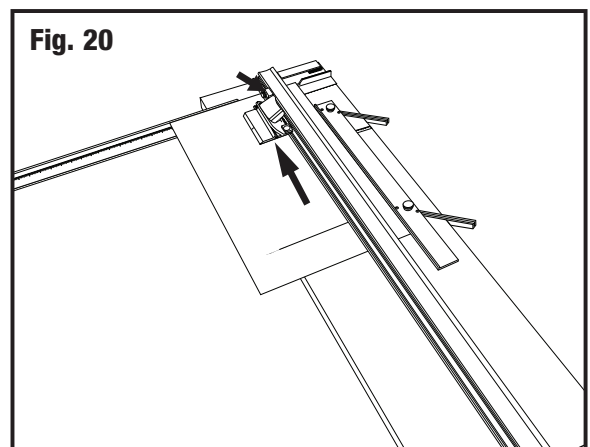
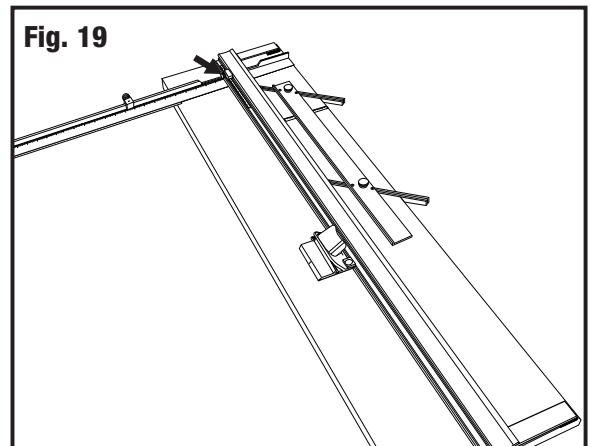

Bevel Cutter Adjustments

Bevel blade depth adjustment

- Increase depth to increase overcuts - Decrease depth to reduce overcuts
1. Hold the 702-1 bevel cutter upside down in your hand with the blade activated in the cutting position.
 2. Measure the exposed amount with a ruler at the same angle as the blade. For standard thickness mat board (4 ply/1.4 mm) only 1/8" of blade should be seen (**Fig. 22**).
 3. Turn blade depth screw (clockwise) to decrease blade depth and (counterclockwise) to increase depth.

NOTE: Seeing roughly 1/8" of blade is usual for most standard thickness matboard; however, yours may need slightly more or less to get best results.

NOTE: Always have blade depth set so that slip sheet is only slightly scored.

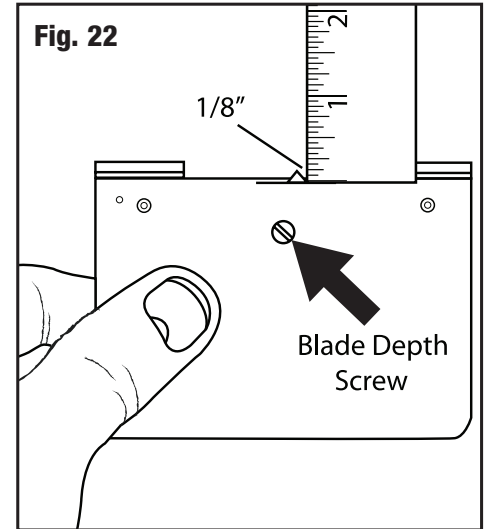

Straight Cut Mat Opening

EXAMPLE: Cutting a mat with a 2" border.

1. Set the mat guide to the 2" mark on the scale and retighten the black knobs.
2. Place the mat to be cut into the machine colored side down with the slip sheet underneath and lower the guide rail.
3. Using a pencil, mark a line along the full length of the mat board using the guide rail as a guide. Repeat this for remaining three sides.
4. Using the straight cutting head, align the top scribe line with the top border line and press down on the handle until the cutting head sits flat on the mat board and the nylon guides hook onto the guide rail lip (**Fig. 23**).
5. Pull the straight cutting head until the bottom scribe line lines up with the bottom border line. Repeat until all borders are cut (**Fig. 24**).

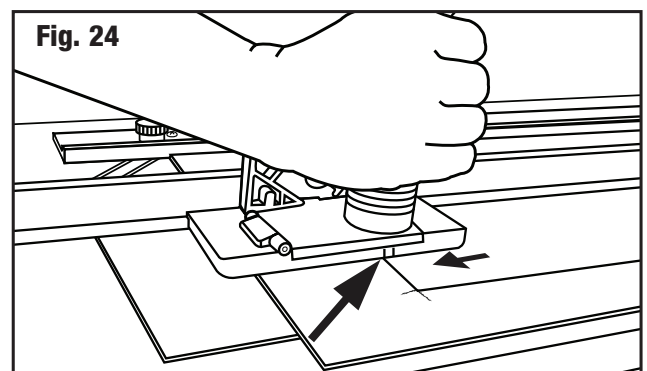
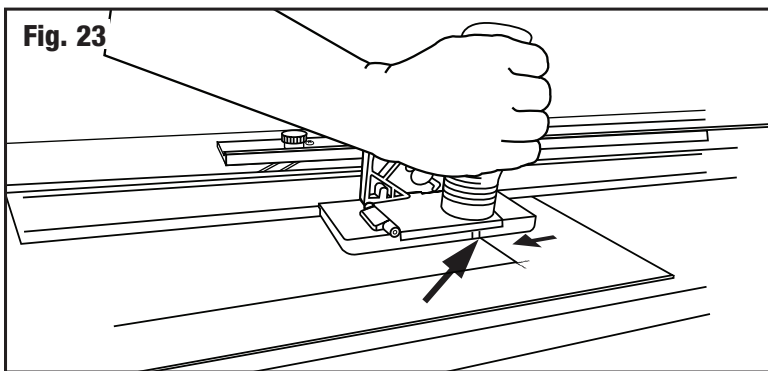



**CAUTION!!
MAT CUTTING BLADES ARE SHARP**

8-Ply Bevel Cutting Instructions

Blade Installation

NOTE: Use only special 8-Ply blade #271. It has only one sharp, beveled edge. DO NOT USE #270 which looks similar but has two beveled edges. The #270 blade will not cut 8-Ply effectively (Fig. 25).

NOTE: Only one corner of blade #271 can be used (Fig. 26).

1. Loosen blade knob and remove cartridge.
2. Set blade onto blade slide, being careful of orientation of edge bevel (Fig. 27).
3. Insert blade slide into cutting head (Fig. 28).
4. Tighten blade knob.

Depth Adjustment

NOTE: Standard 8-Ply depth setting is aligning end of blade with end of slide (Fig. 29).

1. Set cutter onto 8-Ply mat board with blade overhanging edge.
2. Depress blade fully.
3. Corner of blade tip edge should penetrate slip sheet past top of bevel edge (Fig. 30).
4. To adjust depth, loosen blade knob and turn depth adjustment screw.

NOTE: When reducing depth, you will have to push blade back with your finger.

5. Retighten blade knob.

Line to Line Method

1. Move stops out of cutting area or remove from rail.
2. Set the mat guide to the desired border width.
3. Make sure the slip sheet is in place before bevel cutting.
4. Place the mat (color side down) under the Guide Rail and up against the squaring arm and mat guide.
5. Using a pencil, draw a line down the full length of the back of the matboard. Turn the mat after each marking and repeat this for the remaining three sides.

711 Simplex 8-Ply Cutter

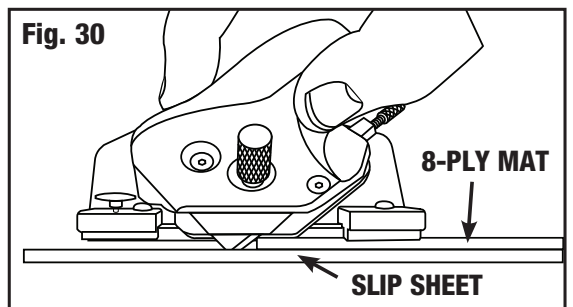
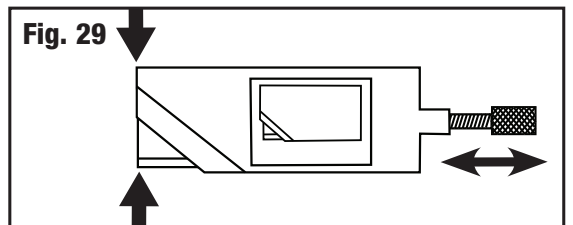
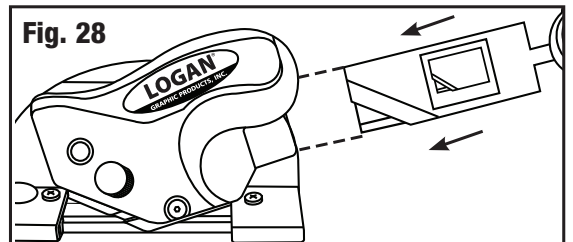
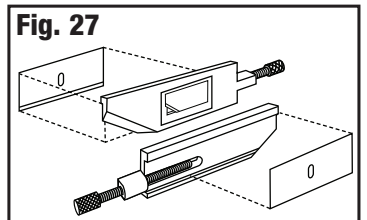
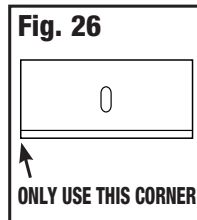
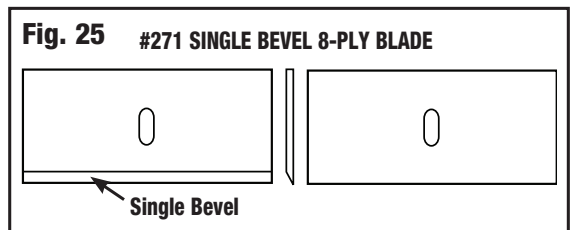
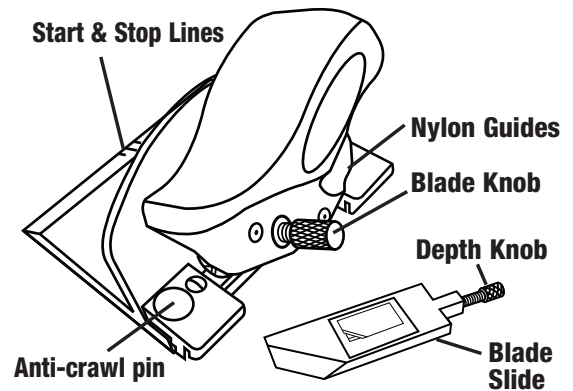

8-Ply Bevel Cutting Instructions

6. Attach the 8-ply cutter to the guide rail by fitting the black nylon guides over the raised edge of the channel.
7. Position the cutter so the GREEN start line lines up with the marked line closest to the top of the pencil line (**Fig. 31**).
8. With left hand, depress the anti-crawl pin and firmly pivot the blade holder down into the mat.

NOTE: It is essential to keep even, downward pressure on the Blade Holder as you cut.

9. Release the anti-crawl pin and, with two hands, pull the cutting head toward you until RED stop line lines up with bottom pencil line (**Fig. 32**).
10. Rotate the blade holder back up to the neutral position and turn the mat 1/4 to the right. Complete this for the remaining three sides.

Helpful Hints

- Use two hands to cut.
- Setting blade depth too deep can result in blade tip chipping off.
- Change blade often.
- Use one blade corner when cutting 8-Ply.
- If you do not cut through the mat, repeat cut.
- If your overcuts are too long or too short, start & stop inside or outside start/stop lines to adjust.

Adjust Nylon Guides (use Phillips Screwdriver)

To improve straightness of cut, you may need to adjust the guides fit on guardrail.

1. Hook cutter onto rail.
2. Loosen guide screws. (**Fig 33**).
3. Squeeze guide against rail.
4. Retighten guide screws.

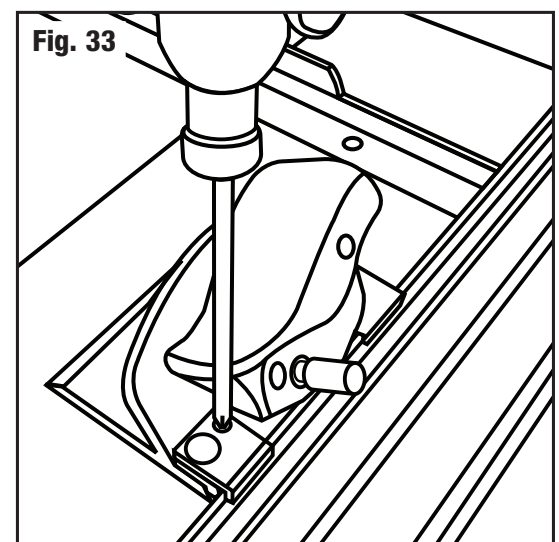
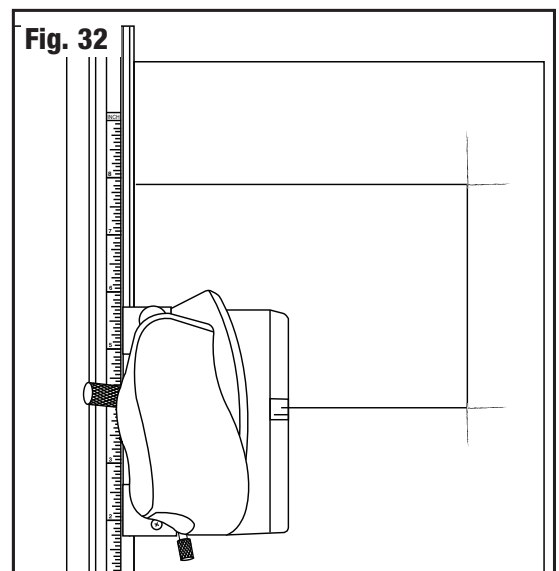
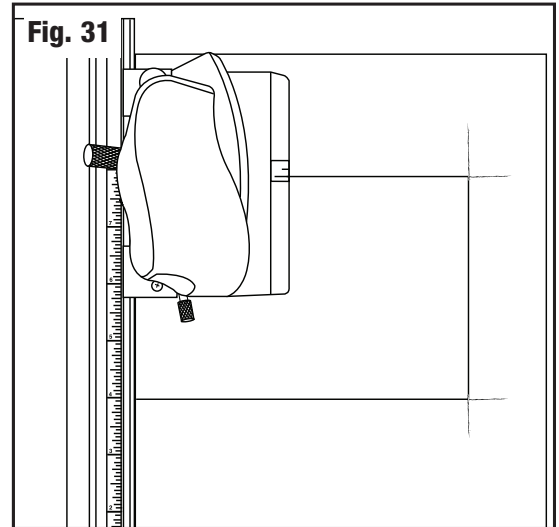

Paper Trimming Instructions



**CAUTION!!
BLADES ARE SHARP**

1. Remove mat guide.
2. Insert slip sheet longer than material to trim.
3. Set squaring arm stop to dimension of cut.
4. Place material under guiderail & against squaring arm stop.
5. Slide paper trimmer onto guiderail (**Fig. 34**).
6. Align trimmer beyond material, press down on blade holder (**Fig. 35**).
7. Keep even, downward pressure & pull cutter across material.

710 Paper Trimmer

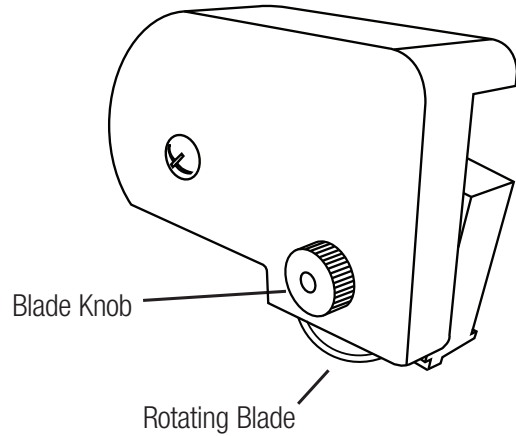

Change Paper Trimmer Rotary Blade

1. Open paper trimmer (**Fig. 36**).
2. Unscrew blade knob.
3. Carefully remove blade screw and blade.
4. Replace blade on screw (Logan replacement blade #2038).
5. Reassemble.

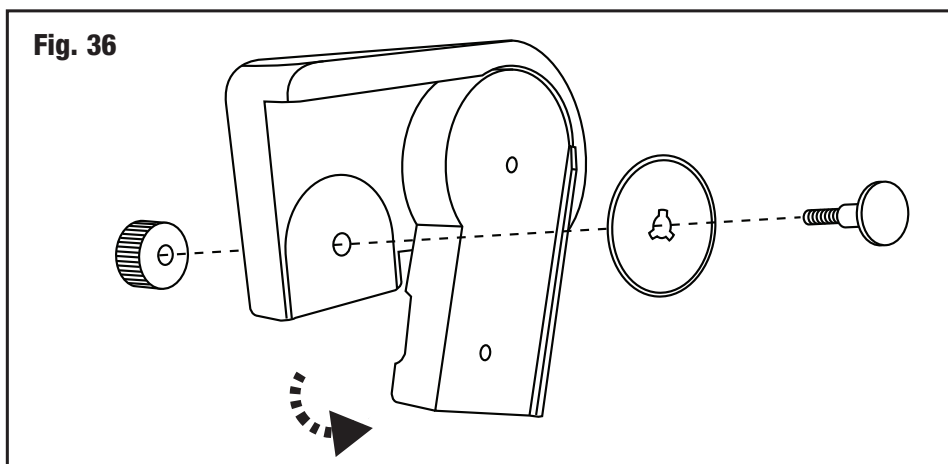
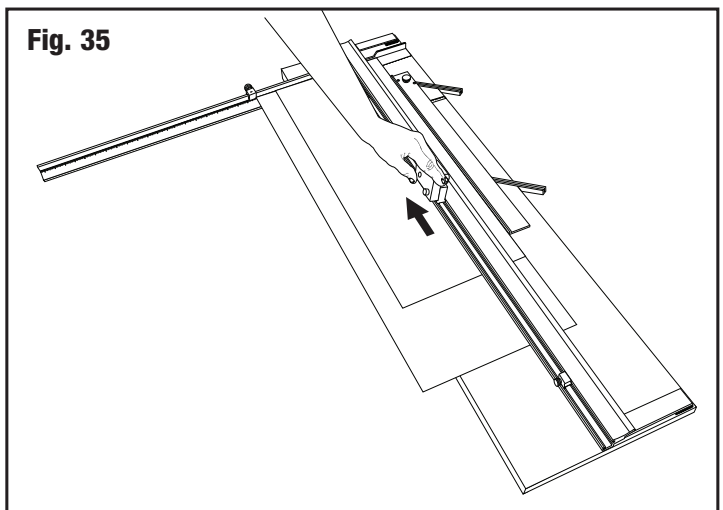
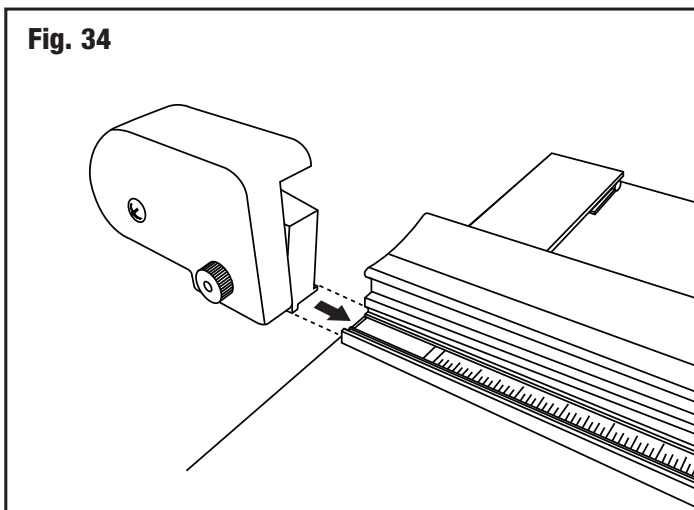



**CAUTION!!
BLADES ARE SHARP**

Plastic Cutting Instructions

709 Acrylic Plastic Cutter

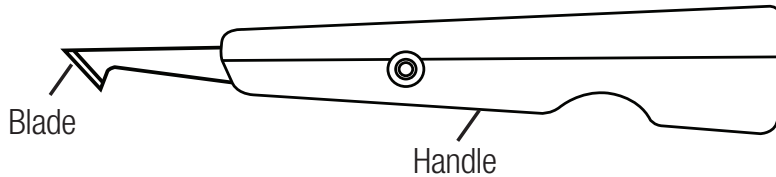

1. Remove mat guide and slip sheet.
2. Slide rail stops to far end of rail or remove.
3. Set squaring arm stop to dimension of cut.
4. Place acrylic sheet under guiderail and against squaring arm.
5. Open cutter from safety setting (**Fig. 37**).
6. Set tip of cutter at edge of plastic and against guide rail (**Fig. 38**) straight edge.
7. Keep even downward pressure and against guiderail, pull cutter across plastic completely (**Fig. 39**).
8. Repeat two more times.
9. Slide plastic to align score with edge of board (**Fig. 40**).
10. Press down firmly on overhanging plastic to separate (**Fig. 41**).

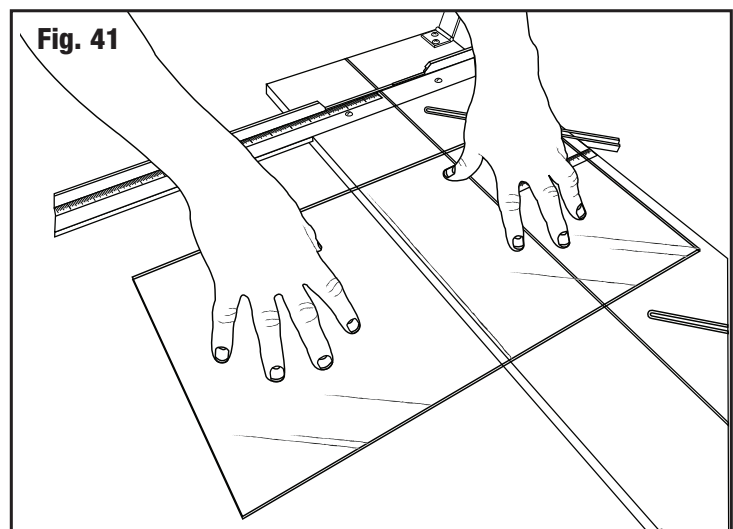
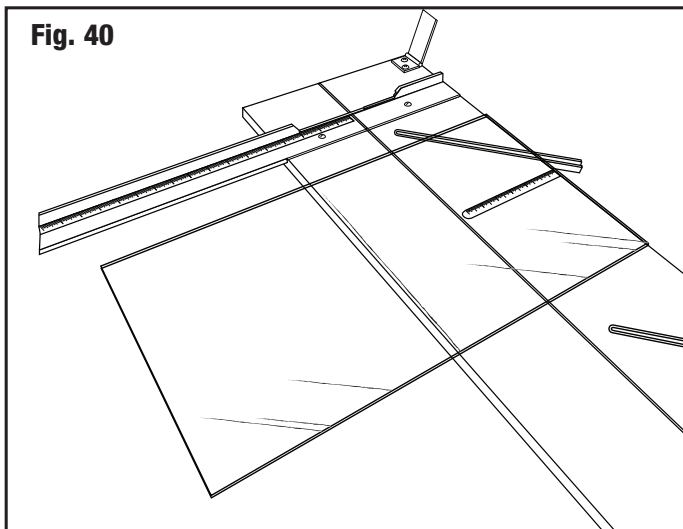
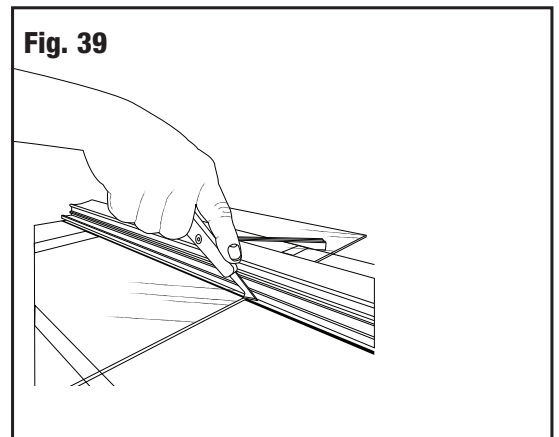
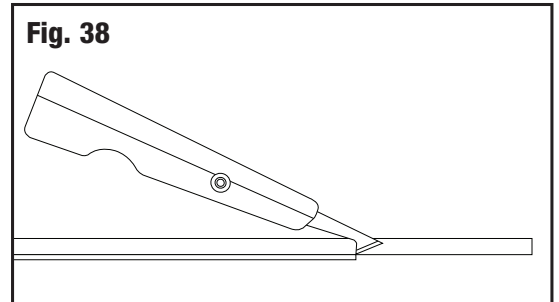
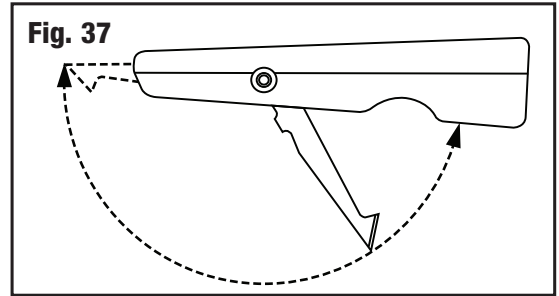

Glass Cutting Instructions

1. Remove mat guide and slip sheet.
2. Slide rail stops to top of rail or remove (**Fig. 42**).
3. Set squaring arm stop to dimension of cut.
4. Place clean glass under guide rail (**Fig. 43**) and against squaring arm.
5. Squeeze a drop of cutting oil onto glass wheel (**Fig. 44**).
6. Hook glass cutter onto guide rail past end of glass. Pull cutter until wheel hits glass (**Fig. 45**).
7. Pull glass cutter, keeping even constant downward pressure. Press hard enough to score glass but not to flake or chip surface.

NOTE: Only score glass once. Do not retrace score.

8. Slide glass to align score with edge (**Fig. 46**) of board.
9. Press down on overhanging glass to separate (**Fig. 47**).

Change Glass Cutting Wheel

1. Loosen wheel shaft knob (**Fig. 48**).
2. Carefully remove wheel and shaft.
3. Slide wheel off shaft (**Fig. 49**).
4. Replace new wheel on shaft.
5. Reassemble.

704-1 Glass Cutter

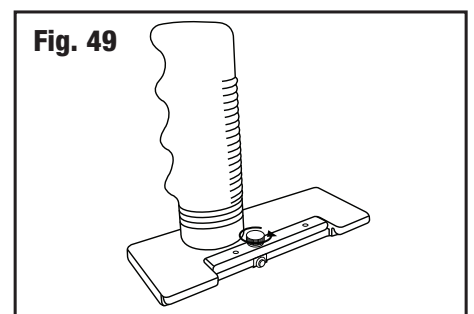
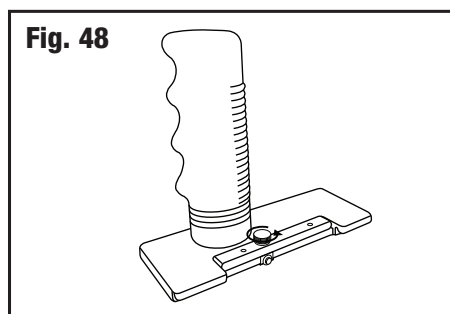
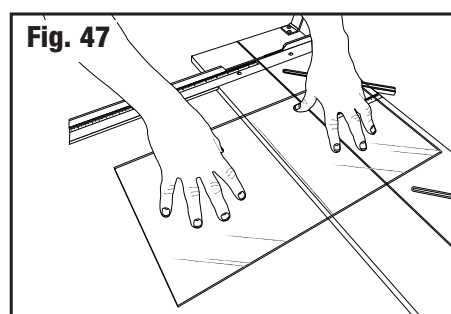
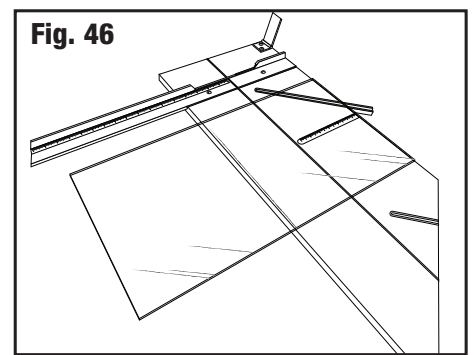
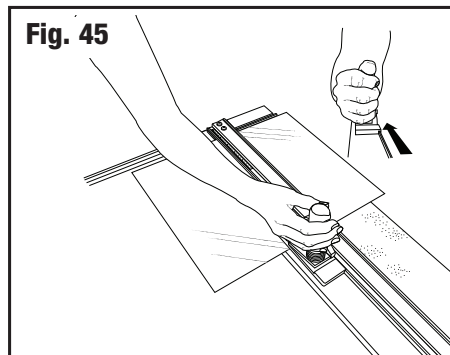
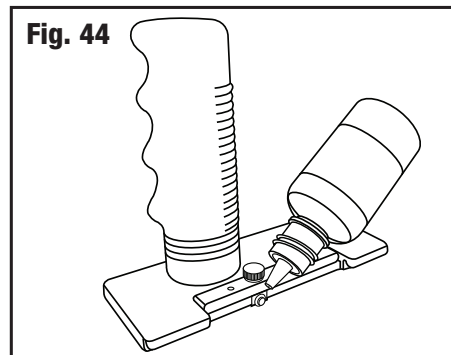
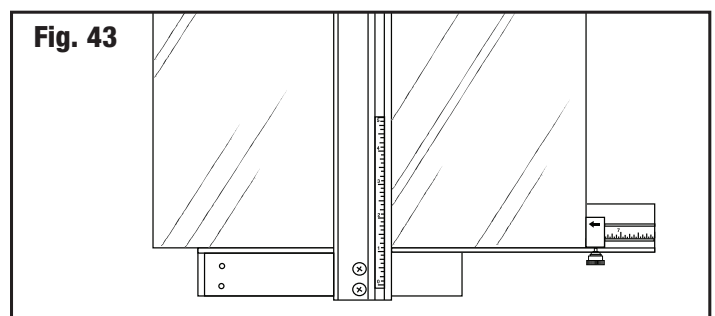
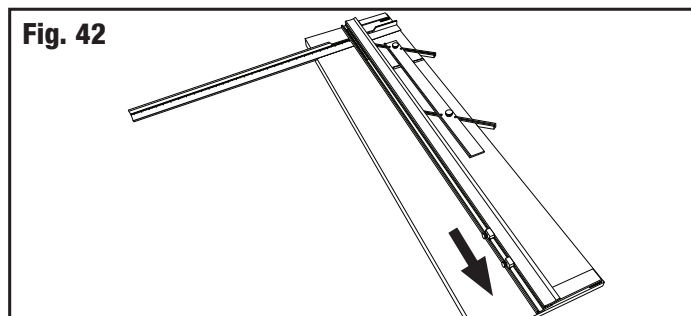
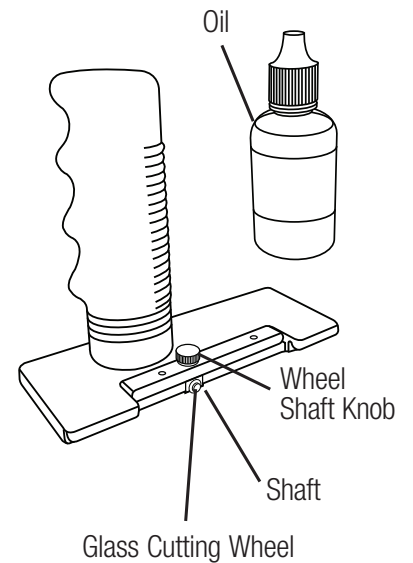

Cutting Board Adjustments

Re-Squaring the Squaring Arm

Tools needed: Screwdriver, Carpenter's Square

Before making any adjustments to the squaring arm, make sure that the machine is truly out of square, not the mat board, by using the squareness test.

ATTENTION: It is common for 32" x 40" sheets of mat board to be un-square when bought. Take this into account before making any adjustments to the squaring arm.

Squareness Test

1. Place the carpenter's square against the right hand side of the guide rail and down against the squaring arm (Fig. 50). Look to see if there are any gaps between the carpenter's square and the squaring arm. If so, the squaring arm needs to be adjusted.

To Re-Square

1. By looking at where the gap is, you can determine which way the squaring arm needs to go, in order to be square again.
2. Remove the squaring arm and locate the two screws inside of the slot.
3. To adjust, you must turn screws A & B in equal but opposite directions. To move the far right end of the squaring arm towards the top end of the machine, turn adjustment screw B inward (clockwise) about a quarter turn, and turn adjustment screw A outward (counter-clockwise) a quarter turn (Fig. 51).
4. Re-install the squaring arm and check for square. This is a trial and error method. In some cases more than a quarter turn is needed, in some cases, less.

Mat Guide Assembly

If mat guide wedge becomes unscrewed from mat guide, reassemble making sure angle of wedge is aligned correctly (Fig. 52).

Re-parallel Mat Guide

Tools Needed: Phillips Screwdriver, Ruler

To re-parallel the mat guide, first determine that the mat guide is out of parallel by doing a parallel test.

Parallel Test:

1. Lock the mat guide at the 2" mark on the scale (Fig. 53).
2. Place a scrap piece of matboard under the guide rail and up against the mat guide at the far end of the machine.
3. Using a pencil, mark a line across the matboard.
4. Slide the mat all the way down near where you are standing, keeping the matboard under the guide rail.
5. Mark another line across the matboard.
6. The piece of matboard should now appear to only have one single line across it. If the two lines drawn do not line up with each other, the mat guide needs to be re-parallelled.

To Re-parallel:

1. Release the mat guide.
2. Use a Phillips head screwdriver to loosen the four screws on either side of the black knobs one turn.
3. Place a ruler or straight edge between the mat guide and the guide rail (Fig. 54).
4. Slide the mat guide against the straight edge and the guide rail. Make sure both the mat guide and the guide rail are making solid contact on both sides of the straight edge.
5. Re-tighten the black knobs first.
6. Then re-tighten the four screws. Do another parallel test to ensure that the mat guide is now parallel.

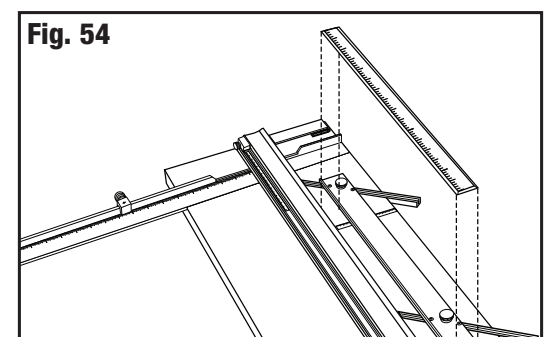
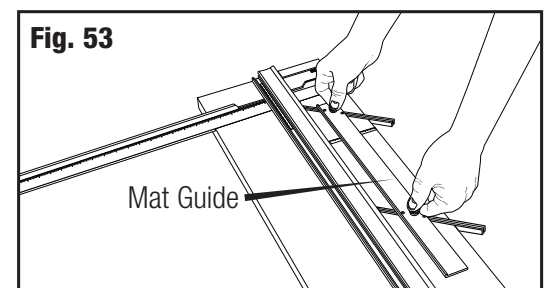
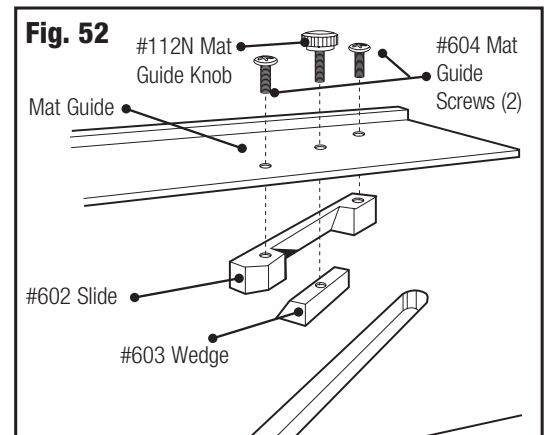
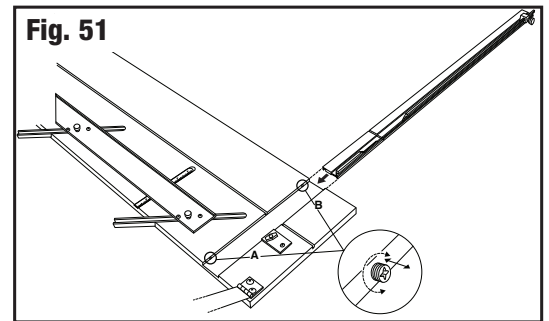
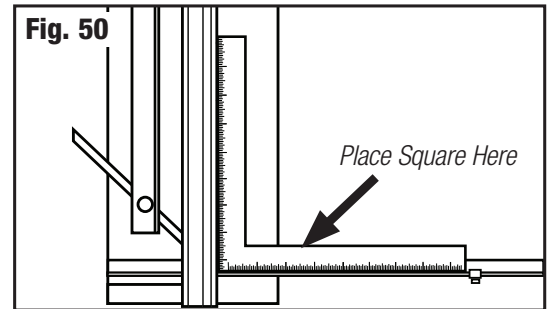

Trouble Shooting

Problem	Solution
Hooks or Curves	Blade depth set too deep. Blade is dull. Blade is catching on previous cut in Slip Sheet. Uneven pressure being applied to Cutting Head during cut.
Overcut on Top Cut	Blade depth set too deep.
Overcut on Bottom Cut	If too small - align start and stop indicator slightly below pencil line and cut. If too big - align start and stop indicator slightly above pencil line and cut.
Mat Borders Uneven	Mat Guide is not parallel.
Ragged Bevel Cut	Cutting without a Slip Sheet. Slip Sheet is worn out. Not changing the blade often enough.
Not Cutting Through	Machine not on a level surface. Not using a Slip Sheet that is as least as long as the mat you are cutting. Blade depth set too shallow.

Helpful Hints

Avoid Board Warp - Always store your mat cutter flat.

Clean Guide Rail - Only use evaporative solvents such as lighter fluid or alcohol. Do not lubricate the guide rail: lubricants will soften the nylon guides and cause them to bind on guide rail.

Cutting a Border Less Than 3/4"
- Mark mat (back side) using a pencil and do not use mat guide.

Blade Life - Use only authentic Logan blades to ensure best results. No two blades last the same amount of time. Size of mats and differences in mat board effect blade life. It is best practice to use a new blade whenever starting a new project.

Warranty

Logan Graphic Products, Inc. ("Logan") warrants the 750-1/760-1 SIMPLEX ELITE to be free from defects in parts and workmanship for a period of two years from the date of original purchase. Logan warrants that it will either repair or replace, in its sole discretion, any necessary replacement parts found to be defective. Should the product need to be returned to Logan for repair or replacement parts, authorization for any return must come from Logan in writing. Costs of returning the product to Logan, including insurances, shall be borne by the purchaser. Logan shall not be liable for any damages or losses, incidental or consequential, direct or indirect, arising from the use of this product. This warranty extends only to the original purchaser and is not assignable or transferable. This warranty is in lieu of all other warranties, expressed or implied. **Be advised that any Logan products purchased as "new" from an unauthorized dealer, such as an online auction site or similar, may be void of their warranty.**

Logan Graphic Products, Inc.
1100 Brown Street Wauconda, IL 60084 | 800-331-6232 847-526-5515

