

PICTURE FRAMING

PRECISION SANDER ELITE

Description

The Model F200-2 Precision Sander Elite has been designed to improve saw cut miters to perfect 45°. A new 10" diameter wheel can accommodate most moulding sizes. After sanding the miters, the result is a sharp seamless frame corner that is of professional quality. The Model F200-2 Precision Sander Elite is a precision tool and will give many years of service. Producing professional quality picture frames is now easier than ever!

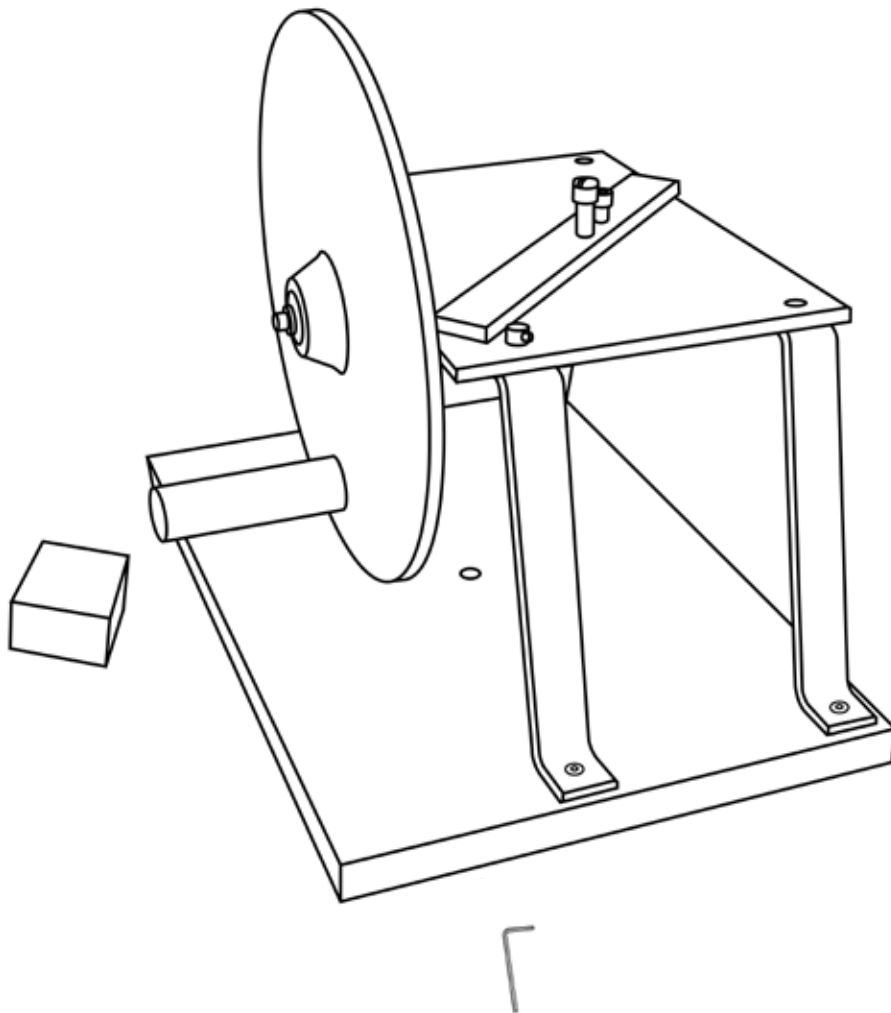

Identification

- A. Wheel** - 10 lb. wheel which rotates in either direction for sanding.
- B. Handle** - Handle to rotate wheel.
- C. Alignment Bar** - Fence stop that the frame lines up against for sanding.
- D. Micro-stops** - Alignment bar adjustments for perfect 45° angles.
- E. Cleaning Bar** - Used to loosen built-up saw dust on sanding wheel.
- F. Micro Stop Wrench**

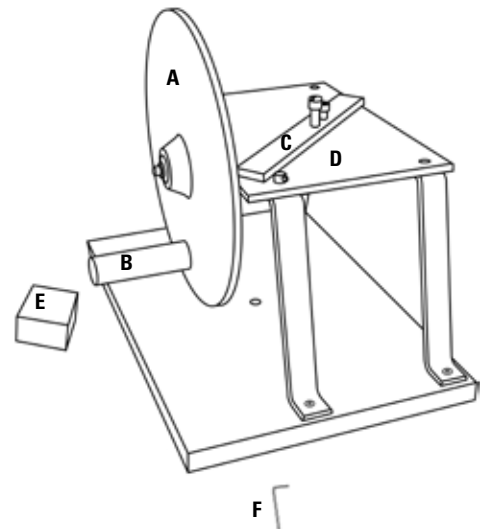

Assembly

1. Remove sanding wheel from base board using wrench. SAVE BOLT (Fig. 1).
2. Discard washers and nut.
3. Attach sanding wheel to top plate using bolt and wrench from step 1 (Fig. 2).

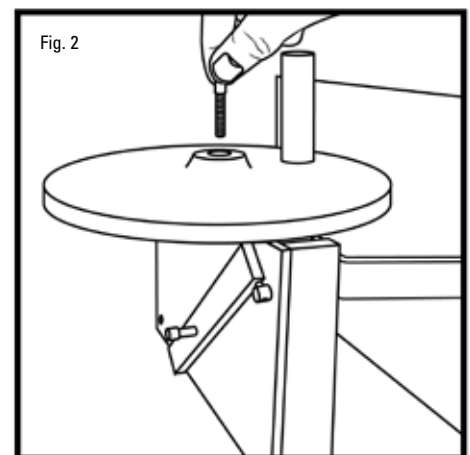
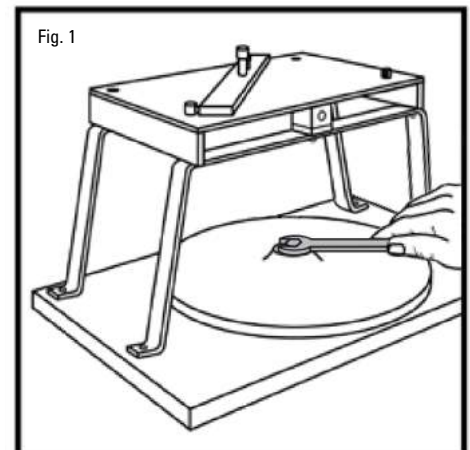

Operation

Preparation

1. Rotate alignment bar to either side by lifting and turning (Fig. 3)

Sanding

1. Place back of moulding against alignment bar with finish side up.
2. Slide moulding against wheel.
3. With one hand, hold moulding firmly against alignment bar and wheel. With other hand, rotate wheel in the direction of the moulding or downward onto the top of the moulding. (Figs. 4a and 4b)

4. Rotate wheel 4-6 times.

- *Adjust the pressure against the wheel while rotating. Start with light pressure until wheel is spinning, then increase the pressure for easier sanding.*



5. Check sanded surface of moulding to see if surface is smooth.
6. Repeat until full surface is smooth.

Check Lengths It is important both sides of moulding are same length for square frame and seamless corners.

1. Lay two moulding pieces side-by-side so miters are facing up.
2. Align the two lower edges.
3. Check to see if the upper edges are even in length (Fig. 5).
4. If not, sand longer piece until it's even with short piece.

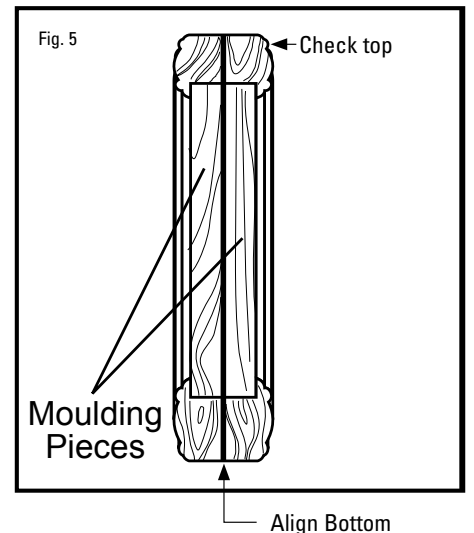
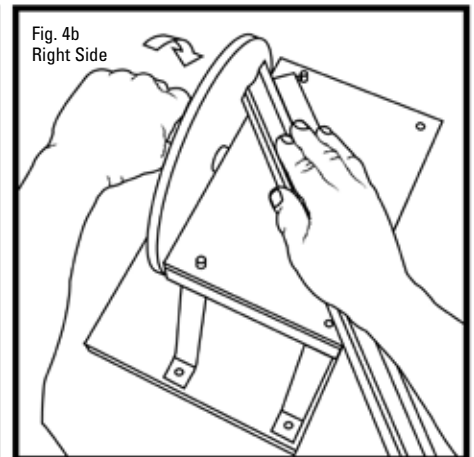
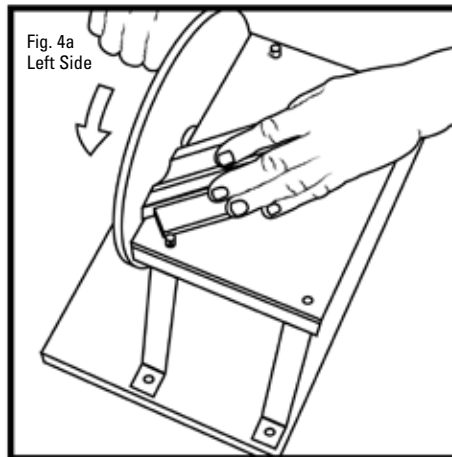
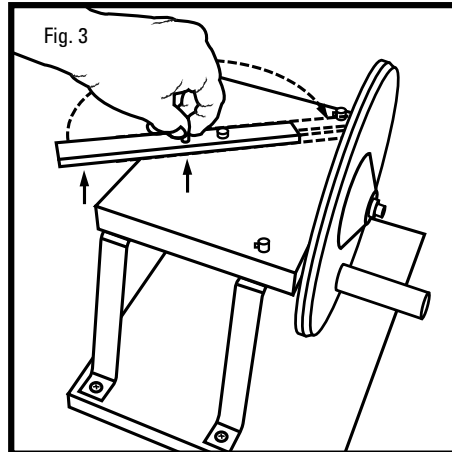

Cleaning

1. Hold the cleaning bar at 45 degrees and move down the length of the wheel while rotating (Fig. 6).
2. Use light pressure. *NOTE: Surface of sandpaper may not look clean but it is. The dust sticks to the backing material not the raised abrasive grit.*

Adjustment 45° (45° triangle not included)

1. Remove sand paper
2. Place a 45° square flat against the wheel and up against bar (Fig. 7). Look for gaps against the bar.
3. Adjust the bar using adjustment wrench until gap disappears.

Changing Disk Paper

1. Remove disk using disk wrench.
2. Remove worn sandpaper and clean surface of disk of any glue or debris using a razor blade or mineral spirits.
3. Peel off adhesive backing and apply sandpaper to disk carefully. Press thoroughly to remove any bubbles.

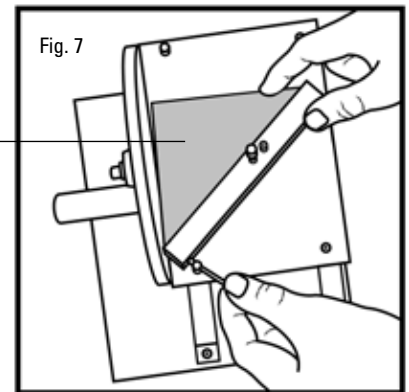
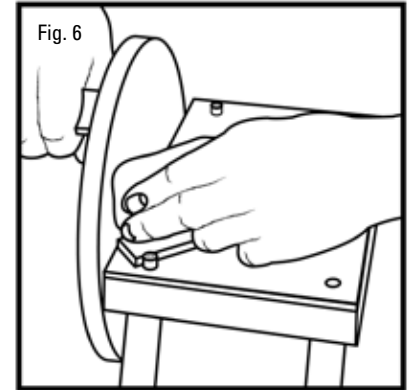

Trouble Shooting

Problem	Solution
Moulding splinters.	Reverse sanding direction. Apply less pressure to surface being sanded.
Not producing 45 degree angle.	Refer to instructions for making adjustments using micro-adjustment blocks. Only small incremental adjustments are required. Remove any debris between moulding and fence. Remove any debris between fence and micro-adjustment stop(s). Make sure center bolt on sanding wheel is tight.
Rough surface after sanding.	Clean sanding disk with supplied cleaning bar. Replace sand paper disk. Apply less pressure to surface being sanded.
Gaps appear in moulding joints.	Sand surface until a fine line of dust appears across the top of the moulding.

Warranty

Logan Graphic Products, Inc. ("Logan") warrants the Precision Sander Elite - Model F200-2, to be free from defects in parts and workmanship for a period of one year from the date of original purchase. Logan warrants that it will either repair or replace, at its' sole discretion, any necessary replacement parts found to be defective. Should the product need to be returned to Logan for repair or replacement parts, authorization for any return must come from Logan in writing. Costs of returning the product to Logan, including insurances, shall be borne by the purchaser. Logan shall not be liable for any damages or losses, incidental or consequential, direct or indirect, arising from the use of this product. This warranty extends only to the original purchaser and is not assignable or transferable. This warranty is in lieu of all other warranties, expressed or implied.