

# ***CRAFT MATERIALS CUTTER***

**INSTRUCTIONS AND OPERATION MANUAL**  
32in (81cm) capacity materials cutting system  
with fixed and rotary cutters.

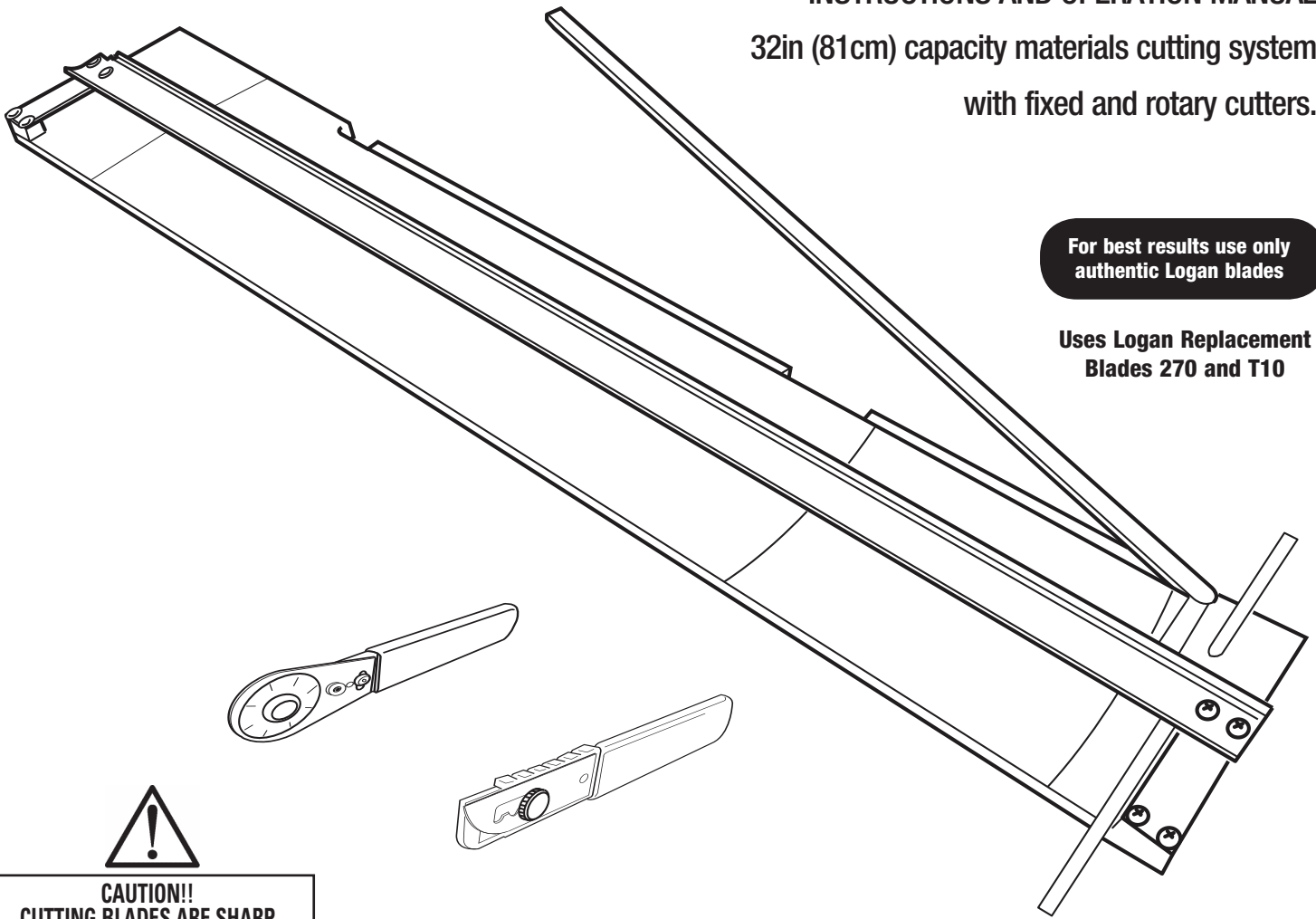

**For best results use only authentic Logan blades**

**Uses Logan Replacement Blades 270 and T10**



**CAUTION!!  
CUTTING BLADES ARE SHARP**



**LoganGraphic.com**

Purchase Date

ID Number (on bottom of board)

Date (on bottom of board)

**Congratulations on your purchase of the Logan Craft Materials Cutter.**

This versatile and dependable tool will prove to be a useful device for those seeking professional results from a low priced, easy to use cutter. This instruction manual is written to acquaint you thoroughly with this product. Please take some time to familiarize yourself with it before cutting. You will find that the time taken will be well worth it and you will be cutting craft materials in no time.

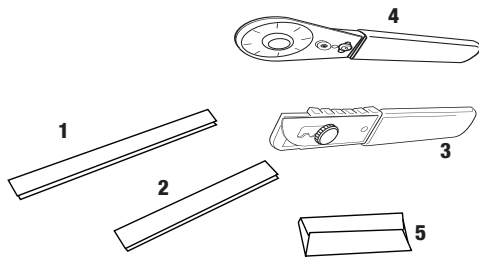

**CARTON CONTENTS:**

1. Squaring Bar - left
2. Squaring Bar - right
3. Fixed Cutter
4. Rotary Cutter
5. Fixed Blades Pack, 270

**Rotary Knife** (showing front and back)

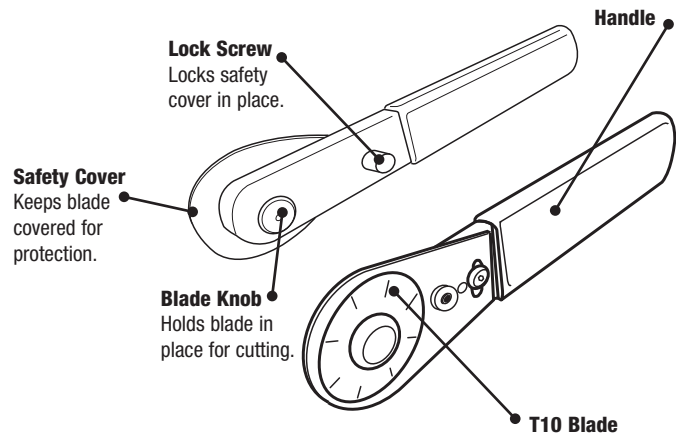

**IDENTIFICATION OF MACHINE COMPONENTS:**

**Cutting Board**

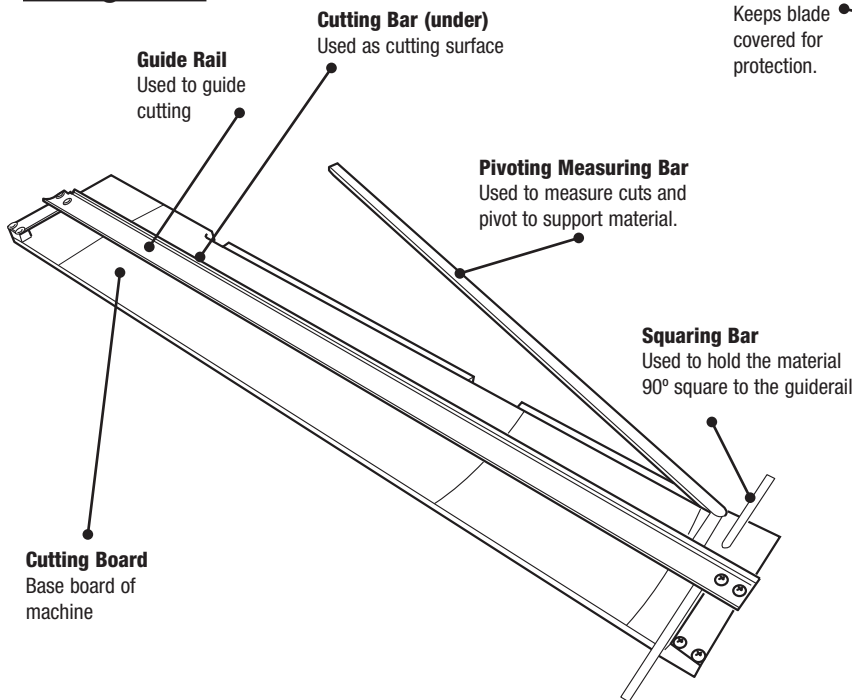

**Fixed Knife**

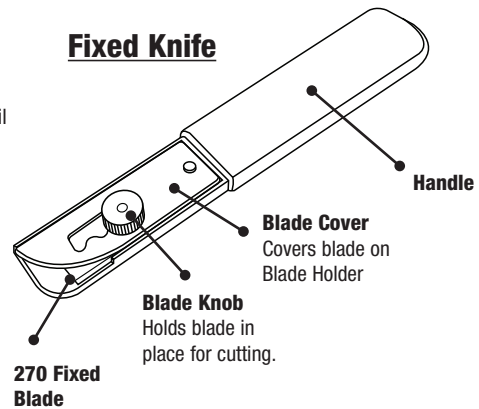

**Warranty**

Logan Graphic Products, Inc. ("Logan") warrants the T100 Craft Materials Cutter to be free from defects in parts and workmanship for a period of two years from the date of original purchase. Logan warrants that it will either repair or replace, in its sole discretion, any necessary replacement parts found to be defective. Should the product need to be returned to Logan for repair or replacement parts, authorization for any return must come from Logan in writing. Costs of returning the product to Logan, including insurances, shall be borne by the purchaser. Logan shall not be liable for any damages or losses, incidental or consequential, direct or indirect, arising from the use of this product. This warranty extends only to the original purchaser and is not assignable or transferable. This warranty is in lieu of all other warranties, expressed or implied. Be advised that any Logan products purchased as "new" from an unauthorized dealer, such as an online auction site or similar, may be void of their warranty.

Logan Graphic Products, Inc.  
 1100 Brown Street Wauconda, IL 60084  
 800/331-6232 847/526-5515

Fig. 1

**Orientation**

The procedures detailed in the following instructions refer to the right & left sides and top & bottom of the machine as shown (Fig. 1).

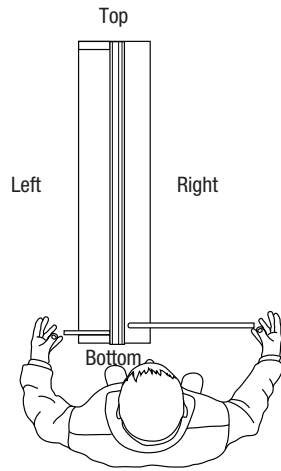

Fig. 2

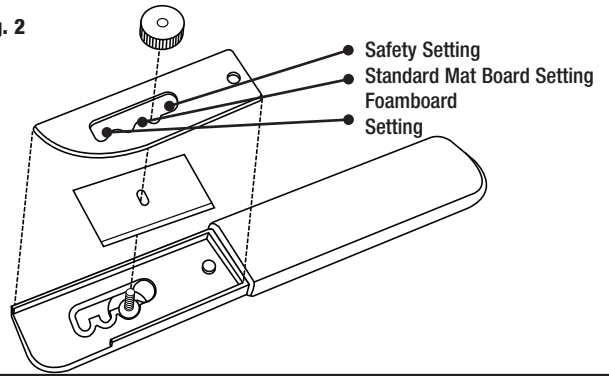

Fig. 3

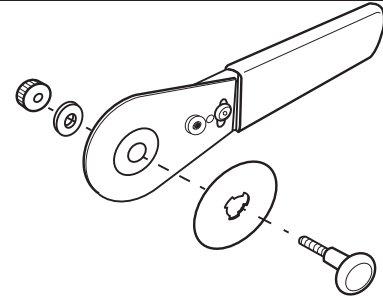

Fig. 4

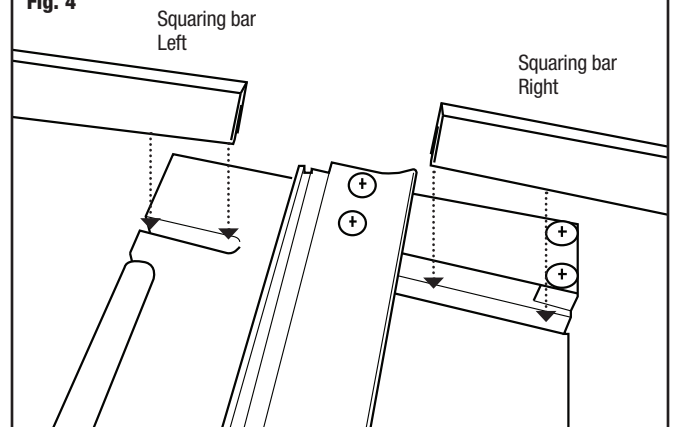

Fig. 5

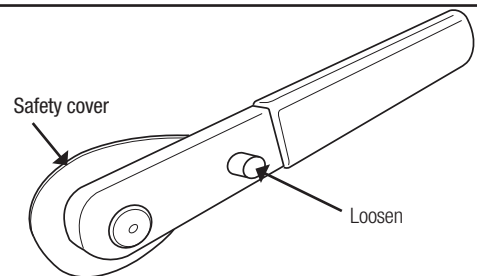
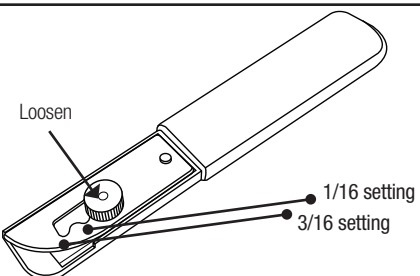

Fig. 6



**Blade Installation - Model 500 Fixed Knife**

1. Remove blade knob and blade cover. (Fig. 2)
2. Align blade hole over thread. Be sure sharp edge of blade is facing down.
3. Reassemble blade cover and blade knob.

**NOTE:** Adjust blade 3/16, 1/16, or safety.

**Blade Change Instructions - Model T50 Rotary Knife**

1. Unscrew nut. (Fig. 3)
2. Remove old blade.
3. Insert new blade.
4. Replace nut.

**Squaring Bar Assembly**

1. Align squaring bars over board slots (Fig. 4).
2. Press bars into slots.

**Preparation**

**Rotary Knife (Fig. 5)**

1. Loosen safety screw one full turn, it will allow safety cover to pivot.
2. After cutting, tighten safety screw to lock safety cover over blade.

**Fixed Knife (Fig. 6)**

1. Loosen knob.
2. Adjust blade depth  
**1/16 setting: chipboard, posterboard, matboard**  
**3/16 setting: cardboard, foamboard**

**Operation**

1. Choose knife to use:  
Fixed Knife: Matboard, cardboard, foamboard, posterboard, chipboard  
Rotary Knife: paper, fabric, photos, film, felt
2. Swing measuring bar perpendicular to board. (Fig. 7)
3. Slide material under guiderail, up against squaring bars and along to desired dimension to cut. (Fig. 8)

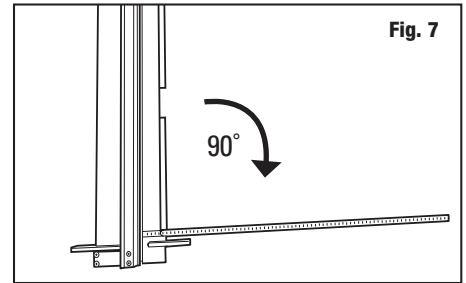

**HELPFUL HINT** Pivot measuring bar under material for support (Fig. 9)

4. Position blade beyond material.

**NOTE:** Both knives cut into plastic cutting bar. Do not remove bar.

5. Pull knife along guidrail keeping even downward pressure. (Fig. 10, 11)

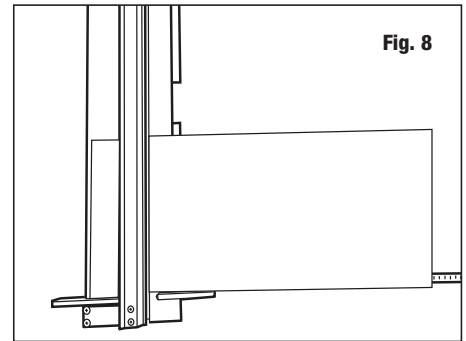

**HELPFUL HINT** Hold knives at slight angle to best keep against rail edge. (Fig. 10, 11)

6. More than one pass may be needed.

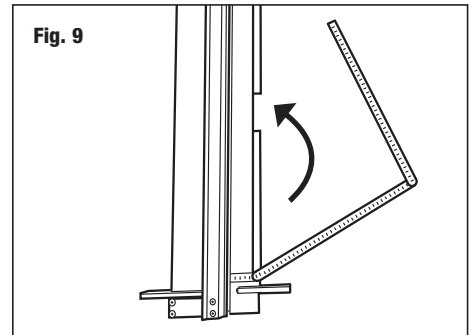

**Maintenance**

**Cutting Bar Wear**

After prolonged use, the cutting bar may need to be changed. All four sides of the bar can be used before replacement.

Order replacement part P2331 Cutting Bar

**To Change:**

1. Lift cutting bar out of slot. (Fig. 12)
2. Rotate 180°. (Fig. 13)
3. Slide bar back into slot aligning hole in bar with pin in slot. (Fig. 14)
4. To use other sides of cutting bar, completely remove cutting bar.
5. Rotate bar back to front. (Fig. 15)
6. Slide new end of bar back into slot.

