

Model WC-2001

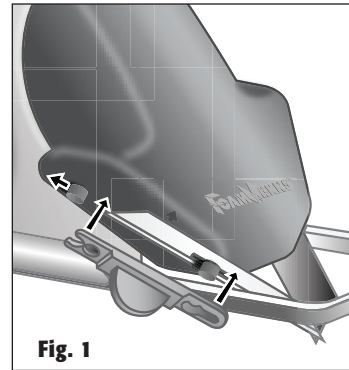
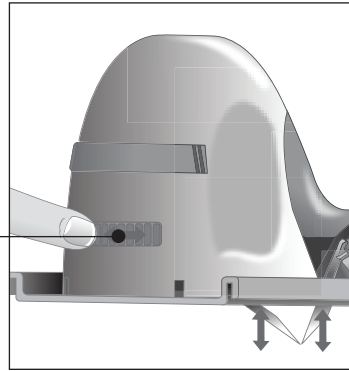
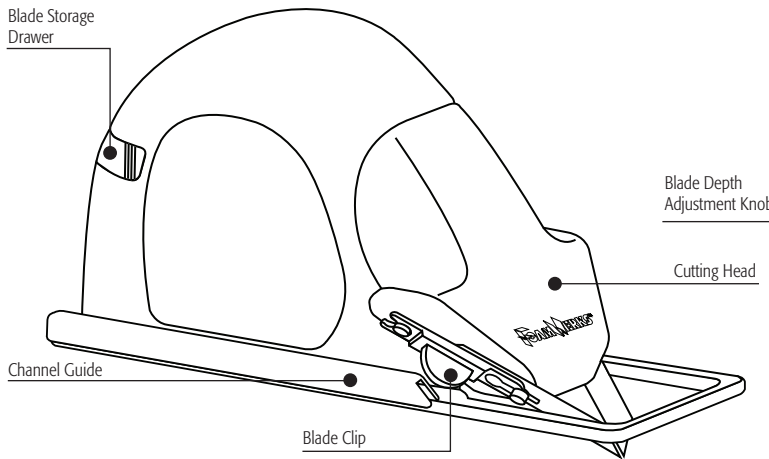

Blade Storage Drawer - Located on the rear of the tool, used to store extra blades
Channel Guide - Clips onto Channel Rail (W-3001) to create accurate, straight cuts
Blade Clip - Used to hold blade in place
Cutting Head - Flexible head that holds blades and is depressed to make V-Groove cut
Blade Depth Adjustment Knob - Raises and lowers blades, which varies the total width of the resulting V-groove cut

OPERATING INSTRUCTIONS

Blade Installation

- 1 Remove the yellow **Blade Clip** by pushing the clip forward.
- 2 Place the blade in the blade depression, matching the blade tip with the angle in the indentation.
- 3 Replace the **Blade Clip**, taking care to position the open end of the clip to the top. Slide upwards until clip snaps into place (**Fig. 1**).
- 4 Repeat for blade on opposite side.

NOTE: Spare blades can be stored in the **Blade Storage Drawer**, located on the back side of the V-Groove Cutter. To open, squeeze the **Blade Storage Drawer** equally from left and right with fingers placed on the drawer ridges.

Cutting

NOTE: Always protect tabletop with a scrap piece of foamboard underneath the board being cut.

- 1 **SAFETY NOTE:** Keep fingers clear of the blade area.
- 2 Using the W-3001 Channel Rail (sold separately, or use the Logan Adapt-A-Rule or Team System), lightly mark the board to indicate the center of the desired V-groove.
- 3 Position the Channel Rail on the foamboard. Hook the **Channel Guide** onto the rail. Align the front and back tick marks to the previously marked line (**Fig. 2 & Fig. 3**).
- 4 With the blades positioned off the top edge of the foamboard, push the **Cutting Head** downward. With **Cutting Head** fully depressed, pull the V-Groove Cutter backwards along the Channel Rail and continue along the length of the foamboard (**Fig. 4**).

Blade Depth Setting

- 1 The blades can be raised or lowered in unison by turning the **Blade Adjustment Knob** found on the back side of the V-Groove Cutter (**Fig. 5**).
- 2 Turn the **Blade Adjustment Knob** to the right to raise the blades, or to the left to lower the blades. Look at the bottom of the V-Groove Cutter, follow the directional arrows. The **Blade Depth Position Scale** provides a rough guide to the blade depth position (**Fig. 6**).

NOTE: Test the blade height by doing a test cut on a scrap piece of foamboard prior to your final cut.

TIP: At some settings, the V-Groove Cutter may cut completely through the foamboard. If this is NOT the effect you desire, be sure to do a test cut prior to your final cut. Note that the V-Groove Cutter cannot cut completely through 1/2" foamboard (1.27cm).

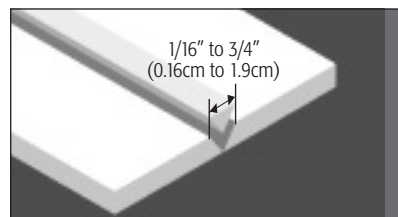
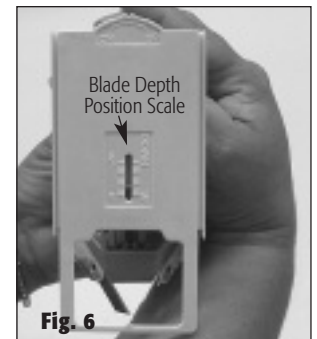
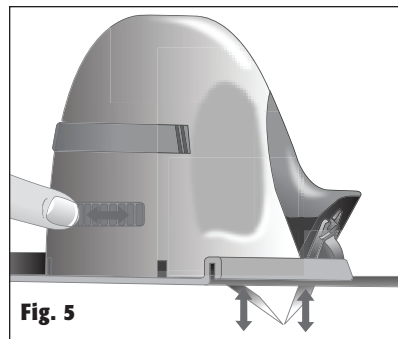
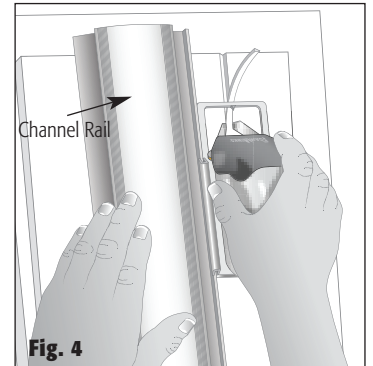
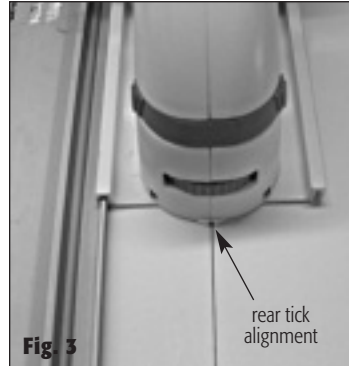
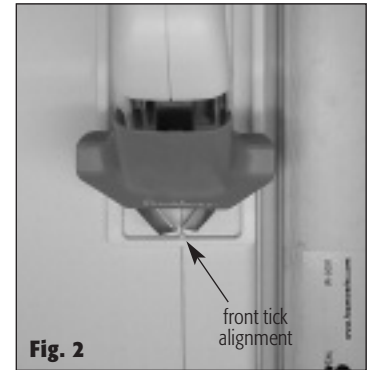

Cuts V-Grooves into foamboard or cellfoam, with resulting V-grooves 1/16" to 3/4" wide (0.16cm to 1.9cm).